



City of Coachella Building and Safety Division

Residential Window Changeout and Emergency Escape/Rescue Opening

Background

Because so many fire deaths occur as the result of occupants of residential buildings being asleep at the time of a fire, Section 1030 of the 2022 California Building Code and Section 310 of the 2022 California Residential Code requires that basements and all sleeping rooms below the fourth story have windows or doors that may be used for emergency escape or rescue in Group R occupancies.

The code intends that the openings required for emergency escape or rescue be located on the exterior of the building so that rescue can be affected from the exterior or, alternatively, the occupants may escape from that opening to the exterior of the building without having to travel through interior of the building in which the normal exit paths are most likely blocked.

Emergency escape and rescue opening requirements

Per section 1030 of the 2022 California Building Code and Section 310 of the 2022 California Residential Code, "Emergency escape and rescue openings shall have a minimum net clear opening of 5.7 sqft. The minimum net clear opening height dimension shall be 24 inches. The minimum net clear opening width dimension shall be 20 inches. Openings shall have the bottom of the clear opening not greater than 44 inches measured from the floor."

The minimum opening size and maximum height from floor is illustrated in the figure below:

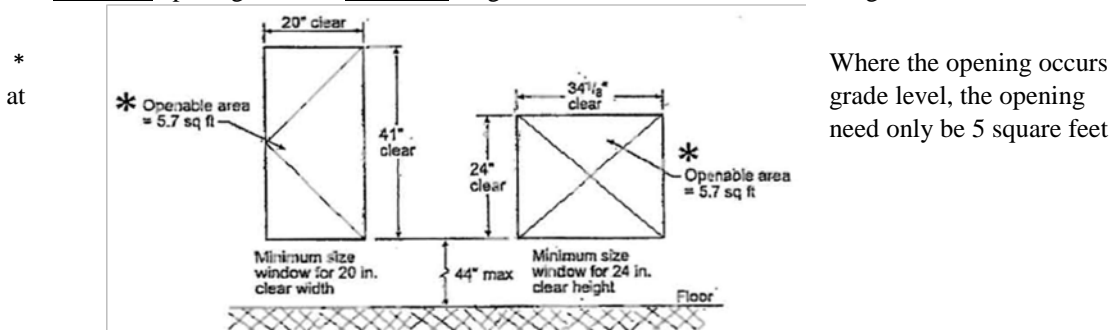

Requirements for Replacing Bedroom Windows in Existing Homes

Construction Year	Bedroom Egress Requirement	Net Opening Size	Min. Opening Dimensions	Max. Height from Floor
Prior to 1964	No	12 sqft (Total Window Sizes in the same room)	None	None
1964 – 1980	Yes	5 sqft (Net)	22" (H) X 22" (W)	48" to Sill
1980 – 12/31/07	Yes	5.7 sqft (Net)	24" X 20"	44" to Sill
01/01/08 – Present	Yes	5.7 sqft (Net) 5 sq. ft. (Grade Level Only)	24" X 20"	44" to Clear Opening

A building permit is required for any window replacement. Some restrictions and/or modifications might be required when replacing or modifying any bedroom window which does not meet the emergency escape and rescue requirements mentioned above. All replacement windows shall comply with California Energy Code with U = 0.3 (max) and SHGC = 0.23 (max) and shall have safety glazing if located in hazardous locations. Battery operated smoke and/or carbon monoxide alarms are required per Sections R314 and R315 of the 2022 California Residential Code, if not already installed.

Requirements for Replacing Doors in Existing Homes

Swinging doors separating conditioned space from outside or adjacent unconditioned space shall have U-Factor = 0.2 (max). Fire rated garage doors are exempt. Glazed doors will be treated as fenestration products. Please contact or consult with City of Coachella Building Department at 760-398-3502 for further information.

Window Schedule

Owner: _____

Address: _____

APN: _____

Legal: _____

Scope of Work: _____

Please draw a Site/Floor Plan of the project site and indicate the location of each window being replaced

Door	Window	Room	Existing Size/Type	New Size/Type	Egress

City of Coachella
53-990 Enterprise Way
City of Coachella, CA 92236
P: 760-398-3502