

CITY OF COACHELLA



PUBLIC WORKS DEPARTMENT

REQUEST FOR PROPOSALS AND CONTRACT DOCUMENTS

FOR

FY 2023-26 On-Call Striping Contract

DUE: October 4, 2022 at 2pm

PROJECT NO. 083122

City of Coachella
Public Works Department
Coachella, CA 92236
760.501.8100
www.coachella.org

CITY OF COACHELLA - NOTICE INVITING PROPOSALS
FY 2023-26 On-Call Striping Contract
PROJECT NO. 083122

NOTICE IS HEREBY GIVEN that the City of Coachella, a municipal corporation, organized under the laws of the State of California, with its principal place of business at 53462 Enterprise Way, Coachella, California 92236 ("City") invites and will receive sealed Proposals up to but not later than **2:00 P.M. on Tuesday, October 4, 2022** at the Public Works Department, located at 53462 Enterprise Way, Coachella, California 92236, for **FY 2023-26 On-Call Striping Contract, City Project No. 083122**, (the "Project"). Bids received after said time shall be returned unopened. Bids shall be valid for a period of 90 calendar days after the proposal deadline.

The City is requesting proposals to provide: on-call striping services. The contract amount for FY 2022-23 is \$120,000. The usages of the services are on an as-needed basis, so if the demand is not there, then the services will not be requested. There is no guarantee for work. The City reserves the right to reject any or all proposals determined not to be in the best interest of the City. All work to be constructed and performed in a workmanlike, professional manner, and to the satisfaction of the City.

Interested proposers may download copies of the Contract Documents by visiting the City's web site, <https://www.coachella.org/services/proposals-bids>. Electronic specifications and bidder's forms for bidding this project can only be obtained at the City of Coachella website or by calling (760) 501-8100. There is no cost for the contract documents. It is the responsibility of each prospective bidder to check the website periodically for updates, such as Addenda.

Each Proposal shall be accompanied by cash, a certified or cashier's check, or Bid Bond secured from a surety company satisfactory to the City, the amount of which shall not be less than ten percent (10%) of the amount bid, made payable to City of Coachella as bid security. The bid security shall be provided as a guarantee that within ten (10) calendar days after City provides the successful bidder the Notice of Award, the successful Bidder will enter into a contract and provide the necessary bonds and certificates of insurance. The bid security will be declared forfeited if the successful Bidder fails to comply within said time. No interest will be paid on funds deposited with City.

The successful Bidder will be required to furnish a Faithful Performance Bond and a Labor and Material Payment Bond each in an amount equal to one hundred percent (100%) of the Contract Price. Each bond shall be in the forms set forth herein, shall be secured from a surety company that meets all State of California bonding requirements, as defined in California Code of Civil Procedure Section 995.120, and that is a California admitted surety insurer.

Pursuant to Section 22300 of the Public Contract Code of the State of California, the successful Bidder may substitute certain securities for funds withheld by City to ensure its performance under the Contract.

Pursuant to Labor Code Section 1773, City has obtained the prevailing rate of per diem wages and the prevailing wage rate for holiday and overtime work applicable in Riverside County from the Director of the Department of Industrial Relations for each craft, classification, or type of worker needed to execute this contract. A copy of these prevailing wage rates may be obtained via the internet at: www.dir.ca.gov/dlsr/. The successful Bidder shall post a copy of the prevailing wage rates at each job site. It shall be mandatory upon the Bidder to whom the Contract is

awarded, and upon any subcontractors, to comply with all Labor Code provisions, which include but are not limited to the payment of not less than the said specified prevailing wage rates to all workers employed by them in the execution of the Contract, employment of apprentices, hours of labor and debarment of contractors and subcontractors.

Pursuant to Labor Code sections 1725.5 and 1771.1, all contractors and subcontractors that wish to bid on, be listed in the bid proposal, or enter into a contract to perform public work must be registered with the Department of Industrial Relations. No Proposal will be accepted nor any Contract entered into without proof of the contractor's and subcontractors' current registration with the Department of Industrial Relations to perform public work. If awarded a contract, the Bidder and its subcontractors, of any tier, shall maintain active registration with the Department of Industrial Relations for the duration of the Project. Notwithstanding the foregoing, the contractor registration requirements mandated by Labor Code Sections 1725.5 and 1771.1 shall not apply to work performed on a public works project that is exempt pursuant to the small project exemption specified in Labor Code Sections 1725.5 and 1771.1.

This Project is subject to compliance monitoring and enforcement by the Department of Industrial Relations. In bidding on this Project, it shall be the Bidder's sole responsibility to evaluate and include the cost of complying with all labor compliance requirements under this contract and applicable law in its Bid.

Pursuant to SB854, all contractors and subcontractors must furnish electronic certified payroll records directly to the Labor Commissioner (aka Division of Labor Standards Enforcement). All contractors and subcontractors must also provide a copy and proof of the online submittal to the City within 2 days of online submission. Failure to do so may result in the withholding of payments by the City until such time that all Certified Payrolls to date have been submitted to the DIR and the City.

Unless otherwise provided in the Instructions for Proposers, each Bidder shall be a licensed contractor pursuant to sections 7000 et seq. of the Business and Professions Code in the following classification(s) throughout the time it submits its Proposal and for the duration of the Contract. The City has determined that the General Contractor shall possess a valid Class A and the Contractor or subcontractor must possess a valid C31 Contractor's license at the time that the Proposal is submitted. All subcontractors shall possess valid, suitable licenses for the work they will perform. Failure to possess the specified license(s) shall render the Proposal as non-responsive.

Pursuant to Public Contract Code section 3400(b), if City has made any findings designating certain materials, products, things, or services by specific brand or trade name, such findings and the materials, products, things, or services and their specific brand or trade names will be set forth in the Special Conditions.

For further information or questions, contact Maritza Martinez, Public Works Department, (760) 501-8111, mmartinez@coachella.org.

Please send all formal Requests for Clarification (RFC's) to mmartinez@coachella.org before 5:00 P.M. on Thursday September 22, 2022. No formal RFC's will be accepted after this date and time.

END OF NOTICE INVITING BIDS

INSTRUCTIONS TO PROPOSERS

ARTICLE 1. SECURING DOCUMENTS

Bids must be submitted to City on the Proposal Forms which are a part of the Contract Documents for the Project. Contract Documents may be obtained as specified in the Notice Inviting Bids on the City's website (<https://www.coachella.org/services/proposals-bids>). It is the responsibility of each prospective bidder to check the website periodically for updates, such as Addenda, that were issued by the City prior to the submission of their bid.

ARTICLE 2. EXAMINATION OF SITE AND CONTRACT DOCUMENTS

At its own expense and prior to submitting its Bid, each Bidder shall visit the site of the proposed work and fully acquaint itself with the conditions relating to the construction and labor required so that the Bidder may fully understand the work, including but not limited to difficulties and restrictions attending the execution of the work under the Contract. Each Bidder shall carefully examine the Drawings, and shall read the Specifications, Contract, and all other documents referenced herein and made part of the Contract Documents. Each Bidder shall also determine the local conditions which may in any way affect the performance of the work, including local tax structure, contractors' licensing requirements, availability of required insurance, the prevailing wages and other relevant cost factors, shall familiarize itself with all federal, state and local laws, ordinances, rules, regulations and codes affecting the performance of the work, including the cost of permits and licenses required for the work, and shall make such surveys and investigations, including investigations of subsurface or latent physical conditions at the site or where work is to be performed as may be required. Proposers are responsible for consulting the standards referenced in the Contract Documents. The failure or omission of any Bidder to receive or examine the Contract Documents, forms, instruments, addenda, or other documents, or to visit the site and acquaint itself with conditions there existing shall in no way relieve any Bidder from any obligation with respect to its Proposal or to the Contract and no relief for error or omission will be given except as required under state law. The submission of a Proposal shall be taken as conclusive evidence of compliance with this Article.

ARTICLE 3. INTERPRETATION OF DRAWINGS AND CONTRACT DOCUMENTS

Prospective Proposers unclear as to the true meaning of any part of the Drawings, Specifications or other Contract Documents may submit a written request for interpretation. The prospective Bidder submitting the request is responsible for prompt delivery. **Interpretation of the Drawings, Specifications or other Contract Documents will be made only by a written Addendum duly issued and a copy of such Addenda will be posted on the City's website, <https://www.coachella.org/services/proposals-bids>.** Electronic specifications and bidder's forms for bidding this project can only be obtained at the City of Coachella website. There is no cost for the contract documents. It is the responsibility of each prospective bidder to check the website periodically for updates, such as Addenda. **If a prospective Proposers becomes aware of any errors or omissions in any part of the Contract Documents, it is the obligation of the prospective Bidder to promptly bring it to the attention of the City.**

ARTICLE 4. ADDENDA

The City reserves the right to revise the Contract Documents prior to the Proposal opening date. Revisions, if any, shall be made by written Addenda. All Addenda issued by the City shall be included in the Proposal and made part of the Contract Documents. Pursuant to Public Contract Code Section 4104.5, if the City issues an Addendum which includes material changes to the Project less than 72 hours prior to the deadline for submission of Bids, the City will extend the deadline for submission of Bids. The City may determine, in its sole discretion, whether an Addendum warrants postponement of the Proposal submission date. Any such Addenda will be posted on the City's website, <https://www.coachella.org/services/proposals-bids>. It is the responsibility of each prospective bidder to check the website periodically for updates, such as Addenda. The Bidder shall indicate acknowledgement of the Addenda received prior to bidding, in the space provided in the Proposal Form. Failure to indicate the acknowledgement of all Addenda may be sufficient cause for rejecting the Bid.

ARTICLE 5. ALTERNATE BIDS

If alternate bid items are called for in the Contract Documents, the time required for completion of the alternate bid items has already been factored into the Contract duration and no additional Contract time will be awarded for any of the alternate bid items. The City may elect to include one or more of the alternate bid items, or to otherwise remove certain work from the Project scope of work. Accordingly, each Bidder must ensure that each bid item contains a proportionate share of profit, overhead, and other costs or expenses which will be incurred by the Bidder.

ARTICLE 6. COMPLETION OF PROPOSAL FORMS

Bids shall only be prepared using copies of the Proposal Forms which are included in the Contract Documents. The use of substitute Proposal Forms other than clear and correct photocopies of those provided by the City will not be permitted. Bids shall be executed by an authorized signatory as described in these Instructions to Proposers. In addition, Proposers shall fill in all blank spaces (**including inserting "N/A" where applicable**), and initial all interlineations, alterations, or erasures to the Proposal Forms. Proposers shall neither delete, modify, nor supplement the printed matter on the Proposal Forms nor make substitutions thereon. **USE OF BLACK OR BLUE INK, INDELIBLE PENCIL, OR A TYPEWRITER IS REQUIRED.** Deviations in the Proposal Forms may result in the Proposal being deemed "Non-Responsive".

ARTICLE 7. MODIFICATIONS OF BIDS

Each Bidder shall submit its Proposal in strict conformity with the requirements of the Contract Documents. Unauthorized additions, modifications, revisions, conditions, limitations, exclusions or provisions attached to a Proposal may render it Non-Responsive and may cause its rejection. Proposers shall not delete, modify, or supplement the printed matter on the Proposal Forms, or make substitutions thereon. Oral, telephonic and electronic modifications will not be considered.

ARTICLE 8. SUBCONTRACTORS

The Contractor shall perform, with its own organization, Contract work amounting to at least 50 percent of the Contract Price except that any designated "Specialty Items" may be performed by subcontract and the amount of any such "Specialty Items" so performed will be deducted from the Contract Price before computing the amount required to be performed by the Contractor with its

own organization. "Specialty Items" will be identified by the Agency in the Proposal or in the Special Provisions. Where an entire item is subcontracted, the value of work subcontracted will be based on the Contract Unit Price. This will be determined from the information submitted by the Contractor, and subject to approval of the City.

Failure to list subcontractors may render the Proposal non-responsive and may be grounds for rejection of the bid. Failure to comply with the provisions of the California "Subletting and Subcontracting Fair Practices Act" shall make the Contractor subject to the sanctions as set forth in the Act. Delivery of Contract Documents

Bidder shall set forth the name, address of the place of business, contractor license number, and public works contractor registration number of each subcontractor who will perform work, labor, furnish materials or render services to the bidder on said contract and each subcontractor licensed by the State of California who, under subcontract to bidder, specially fabricates and installs a portion of the Work described in the Contract Documents in an amount in excess of one-half of one percent (0.5%) of the Bidder's Total Bid Price or \$10,000, whichever is greater, and shall indicate the portion of the work to be done by such subcontractor in accordance with Public Contract Code Section 4104. If a Bidder fails to specify a subcontractor or if a Bidder specifies more than one subcontractor for the same portion of work, then the Bidder shall be deemed to have agreed that it is fully qualified to perform that portion of work and that it shall perform that portion itself. **If the contractor intends to "Self Perform" all of the work and not utilize any subcontractors, the contractor shall then mark or insert "N/A" on the Subcontractor List form to indicate that the contractor does not intend to utilize any subcontractors to perform any portions of the work. Failure to do so, may deem the Proposal "Non-Responsive".**

Substitution of listed subcontractors shall only be permitted in accordance with Public Contract Code Section 4107.

ARTICLE 9. LICENSING REQUIREMENTS

Pursuant to Business and Professions Code Section 7028.15 and Public Contract Code Section 3300, all Proposers must possess proper licenses for performance of this Contract. Subcontractors must possess the appropriate licenses for each specialty subcontracted. Pursuant to Business and Professions Code Section 7028.5, the City shall consider any Proposal submitted by a Bidder not currently licensed in accordance with state law and pursuant to the requirements found in the Contract Documents to be nonresponsive, and the City shall reject the Bid. The City shall have the right to request, and Proposers shall provide within ten (10) calendar days, evidence satisfactory to the City of all valid license(s) currently held by that Bidder and each of the Bidder's subcontractors, before awarding the Contract.

Notwithstanding anything contained herein, if the Work involves federal funds, the Contractor shall be properly licensed by the time the Contract is awarded, pursuant to the provisions of Public Contract Code section 20103.5.

ARTICLE 10. PROPOSAL GUARANTEE (BOND)

Each Proposal shall be accompanied by: (a) cash; (b) a certified or cashier's check made payable to City of Coachella; or (c) a Bid Bond secured from a surety company satisfactory to the City, the amount of which shall not be less than ten percent (10%) of the Total Proposal Price, made payable to City of Coachella as Bid security. Personal sureties and unregistered surety

companies are unacceptable. The surety insurer shall be California admitted surety insurer, as defined in Code of Civil Procedure Section 995.120. The Proposal security shall be provided as a guarantee that within ten (10) Days after the City provides the successful Bidder the Notice of Award, the successful Bidder will enter into a Contract and provide the necessary bonds and certificates of insurance. The bid security will be declared forfeited if the successful Bidder fails to comply within said time, and the City may enter into a Contract with the next lowest responsive responsible bidder, or may call for new Bids. No interest shall be paid on funds deposited with the City. The City will return the security accompanying the Bids of all unsuccessful Proposers no later than 60 calendar days after award of the contract.

ARTICLE 11. IRAN CONTRACTING ACT OF 2010

In accordance with Public Contract Code Section 2200 *et seq.*, the City requires that any person that submits a Proposal with the City of one million dollars (\$1,000,000) or more, certify at the time the Proposal is submitted that the person is not identified on a list created pursuant to subdivision (b) of Public Contract Code Section 2203 as a person engaging in investment activities in Iran described in subdivision (a) of Public Contract Code Section 2202.5, or as a person described in subdivision (b) of Public Contract Code Section 2202.5, as applicable.

The form of such Iran Contracting Certificate is included with the Proposal Forms and must be signed and dated under penalty of perjury.

ARTICLE 12. NONCOLLUSION DECLARATION

Proposers on all public works contracts are required to submit a declaration of noncollusion with their Bid. This form is included with the Proposal Forms and must be signed and dated under penalty of perjury.

ARTICLE 13. PUBLIC WORKS CONTRACTOR DIR REGISTRATION CERTIFICATION

Pursuant to Labor Code sections 1725.5 and 1771.1, all contractors and subcontractors that wish to bid on, be listed in a bid proposal, or enter into a contract to perform public work must be registered with the Department of Industrial Relations. No Proposal will be accepted nor any Contract entered into without proof of the contractor's and subcontractors' current registration with the Department of Industrial Relations to perform public work. If awarded a contract, the Bidder and its subcontractors, of any tier, shall maintain active registration with the Department of Industrial Relations for the duration of the Project. To this end, Bidder shall sign and submit with its Proposal the Public Works Contractor DIR Registration Certification on the form provided, attesting to the facts contained therein. Failure to submit this form may render the Proposal non-responsive. In addition, each Bidder shall provide the registration number for each listed subcontractor in the space provided in the Designation of Subcontractors form.

ARTICLE 14. BIDDER INFORMATION AND EXPERIENCE FORM

Each Bidder shall complete the questionnaire provided herein and shall submit the questionnaire along with its Bid. Failure to provide all information requested within the questionnaire along with the Proposal may cause the Proposal to be rejected as Non-Responsive. The City reserves the right to reject any Proposal if an investigation of the information submitted does not satisfy the City that the Bidder is qualified to properly carry out the terms of the Contract.

ARTICLE 15. WORKERS' COMPENSATION CERTIFICATION

In accordance with the provisions of Labor Code Section 3700, Contractor shall secure the payment of compensation to its employees. Contractor shall sign and file with the City a Workers' Compensation Certificate prior to performing the work under this Contract. The form of such Workers' Compensation Certificate is included as part of the Proposal Forms.

ARTICLE 16. SIGNING OF BIDS

All Bids submitted shall be executed by the Bidder or its authorized representative. Proposers may be asked to provide evidence in the form of an authenticated resolution of its Board of Directors or a Power of Attorney evidencing the capacity of the person signing the Proposal to bind the Bidder to each Proposal and to any Contract arising therefrom.

If a Bidder is a joint venture or partnership, it may be asked to submit an authenticated Power of Attorney executed by each joint venturer or partner appointing and designating one of the joint venturers or partners as a management sponsor to execute the Proposal on behalf of Bidder. Only that joint venturer or partner shall execute the Bid. The Power of Attorney shall also: (1) authorize that particular joint venturer or partner to act for and bind Bidder in all matters relating to the Bid; and (2) provide that each venturer or partner shall be jointly and severally liable for any and all of the duties and obligations of Bidder assumed under the Proposal and under any Contract arising therefrom. The Proposal shall be executed by the designated joint venturer or partner on behalf of the joint venture or partnership in its legal name.

ARTICLE 17. SUBMISSION OF SEALED BIDS

Once the Proposal and supporting documents have been completed and signed as set forth herein, they shall be placed, along with the Proposal guarantee and other required materials, in a sealed envelope, addressed and delivered or mailed, postage prepaid, to the Engineering Department of the City before the time and day set for the receipt of Bids. The envelope shall bear the title of the work and the name of the Bidder. No oral or telephonic bids will be considered. **No forms transmitted via the internet, e-mail, facsimile, or any other electronic means will be considered unless specifically authorized by the City as provided herein.** Bids received after the time and day set for the receipt of Bids shall be returned to the Bidder unopened. All bids must be submitted in a sealed envelope, addressed to the City Clerk, with the following annotation:

Bidder's Company Name and Address

This envelope contains a SEALED PROPOSAL for: FY 2023-26 On-Call Striping Contract; Project No. 083122

Proposal Opening: Tuesday October 4, 2022, at 2:00 P.M.

Only where expressly permitted in the Notice Inviting Bids may proposers submit their bids via electronic transmission pursuant to Public Contract Code sections 1600 and 1601. Any acceptable method(s) of electronic transmission shall be stated in the Notice Inviting Bids. The City may reject any Proposal not strictly complying with the City's designated methods for delivery.

ARTICLE 18. OPENING OF BIDS

At the time and place set for the opening and reading of Bids, or any time thereafter, each and every Proposal received prior to the time and day set for the receipt of Bids will be publicly opened and read. The City will leave unopened any Proposal received after the specified date and time, and any such unopened Proposal will be returned to the Bidder. **It is the Bidder's sole responsibility to ensure that its Proposal is received as specified.** Bids may be submitted earlier than the date(s) and time(s) indicated.

The public reading of each Proposal will include the following information:

- A. The name and business location of the Bidder.
- B. The nature and amount of the Proposal security furnished by Bidder.
- C. The Proposal Amount.

Proposers or their representatives and other interested persons may be present at the opening of the Bids. The City may, in its sole discretion, elect to postpone the opening of the submitted Bids. **The City reserves the right to reject any or all Bids and to waive any informality or irregularity in any Bid.**

ARTICLE 19. WITHDRAWAL OF BID

Any Proposal may be withdrawn either personally or by written request, incurring no penalty, at any time prior to the scheduled closing time for receipt of Bids. Requests to withdraw Bids shall be worded so as not to reveal the amount of the original Bid. Withdrawn Bids may be resubmitted until the time and day set for the receipt of Bids, provided that resubmitted Bids are in conformance with the instructions herein.

Bids may be withdrawn after Proposal opening only by providing written notice to the City within five (5) working days of the Proposal opening and in compliance with Public Contract Code Section 5100 *et seq.*, or as otherwise may be allowed with the consent of the City.

ARTICLE 20. PROPOSERS INTERESTED IN MORE THAN ONE BID

No Bidder shall be allowed to make, file or be interested in more than one Proposal for the same work unless Alternate Bids are specifically called for. A person, firm or corporation that has submitted a sub-proposal to a Bidder, or that has quoted prices of materials to a Bidder, is not thereby disqualified from submitting a sub-proposal or quoting prices to other Proposers or from simultaneously submitting its own Proposal as a prime contractor.

ARTICLE 21. SUBSTITUTION OF SECURITY

The Contract Documents call for monthly progress payments for the Work completed. The City will retain a percentage of each progress payment as provided by the Contract Documents. At the request and expense of the successful Bidder, the City will substitute securities for the amount so retained in accordance with Public Contract Code Section 22300.

ARTICLE 22. PREVAILING WAGES

The City has obtained from the Director of the Department of Industrial Relations the general prevailing rate of per diem wages in the locality in which this work is to be performed for each craft or type of worker needed to execute the Contract. These rates are available online at <http://www.dir.ca.gov>. Proposers are advised that a copy of these rates must be posted by the successful Bidder at the job site(s).

ARTICLE 23. DEBARMENT OF CONTRACTORS AND SUBCONTRACTORS

In accordance with the provisions of the Labor Code, contractors or subcontractors may not perform work on a public works project with a subcontractor who is ineligible to perform work on a public project pursuant to Labor Code Sections 1777.1 or 1777.7. Any contract on a public works project entered into between a contractor and a debarred subcontractor is void as a matter of law. A debarred subcontractor may not receive any public money for performing work as a subcontractor on a public works contract. Any public money that is paid to a debarred subcontractor by the Contractor for the Project shall be returned to the City. The Contractor shall be responsible for the payment of wages to workers of a debarred subcontractor who has been allowed to work on the Project.

ARTICLE 24. INSURANCE REQUIREMENTS

Prior to commencing work, the successful bidder shall purchase and maintain insurance as set forth in Article 4 of the General Conditions contained herein.

ARTICLE 25. PERFORMANCE BOND AND PAYMENT BOND REQUIREMENTS

The successful Bidder will be required to furnish a Labor and Material Payment Bond and a Faithful Performance Bond each in an amount equal to one hundred percent (100%) of the contract price. Each bond shall be secured from a surety company that meets all State of California bonding requirements, as defined in California Code of Civil Procedure Section 995.120 and is admitted by the State of California. Each bond shall be accompanied, upon the request of the City, with all documents required by California Code of Civil Procedure Section 995.660 to the extent required by law. All bonding and insurance requirements shall be completed and submitted to the City within ten (10) Days from the date the City provides the successful bidder with the Notice of Award.

ARTICLE 26. SALES AND OTHER APPLICABLE TAXES, PERMITS, LICENSES AND FEES

Contractor and its subcontractors performing work under this Contract will be required to pay California sales tax and other applicable taxes, and to pay for permits, licenses and fees required by the agencies with authority in the jurisdiction in which the Work will be located, unless otherwise expressly provided by the Contract Documents.

ARTICLE 27. FILING OF PROPOSAL PROTESTS

Proposers may file a "protest" of a Proposal with the City. In order for a Bidder's protest to be considered valid, the protest must:

Any Proposal protest must be in writing and received by City at the Public Works Department located at 53462 Enterprise Way, Coachella, California, 92236, before 5:00 P.M., no later than two working days following the Proposal opening (the "Proposal Protest Deadline") and must comply with the following requirements:

- A. General. Only a bidder who has actually submitted a Proposal is eligible to submit a Proposal protest against another bidder. Subcontractors are not eligible to submit Proposal protests. A bidder may not rely on the Proposal protest submitted by another bidder but must timely pursue its own protest. For purposes of this Section 28, a "working day" means a day that City is open for normal business, and excludes weekends and holidays observed by City.
- B. Protest Contents. The Proposal protest must contain a complete statement of the basis for the protest and all supporting documentation. **Material submitted after the Proposal Protest Deadline will not be considered.** The protest must refer to the specific portion or portions of the Contract Documents upon which the protest is based. The protest must include the name, address, email address, and telephone number of the person representing the protesting bidder if different from the protesting bidder.
- C. Copy to Protested Bidder. A copy of the protest and all supporting documents must be concurrently transmitted by fax or by email, by or before the Proposal Protest Deadline, to the protested bidder and any other bidder who has a reasonable prospect of receiving an award depending upon the outcome of the protest. Failure to do so may result in such protest becoming null, void, and ejected by the City.
- D. Response to Protest. **The protested bidder shall submit a written response to the City and protesting bidder provided the response is received by City before 5:00 P.M., within three working days after actual receipt of the Proposal protest (the "Response Deadline").** The response must include all supporting documentation. Material submitted after the Response Deadline will not be considered. The response must include the name, address, email address, and telephone number of the person representing the protested bidder if different from the protested bidder. **If the protested bidder fails to respond prior to the deadline as set forth, the City reserves the right to reject the Proposal and award the project to the next lowest responsive and responsible bidder.**
- E. Copy to Protesting Bidder. **A copy of the response and all supporting documents must be concurrently delivered by hand, mail, or email, to the City, protesting bidder, and any other bidder who has a reasonable prospect of receiving an award depending upon the outcome of the protest before 5:00 P.M., within Three working days after actual receipt of the Proposal protest (the "Response Deadline").** Failure to do so may cause the City to reject the Proposal and award the project to the next lowest responsive and responsible bidder. The City also reserves the right to extend the deadline if conditions or circumstances warrant the extension of such deadline.

If the protest does not comply with each of these requirements, the City may reject the protest without further review.

If the protest is timely and complies with the above requirements, the City shall review the protest,

any response from the challenged Bidder(s), and all other relevant information. The City will provide a written decision to the protestor.

The procedure and time limits set forth in this Article are mandatory and are the sole and exclusive remedy in the event of a Proposal protest. Failure to comply with these procedures shall constitute a failure to exhaust administrative remedies and a waiver of any right to further pursue the Proposal protest, including filing a Government Code Claim or legal proceedings.

ARTICLE 28. BASIS OF AWARD; BALANCED BID

The City shall award the Contract to the lowest responsible Bidder submitting a responsive Bid. The lowest Proposal will be determined on the basis of the Total Proposal Price.

The City may reject any Proposal which, in its opinion when compared to other Bids received or to the City's internal estimates, does not accurately reflect the cost to perform the Work. The City may reject as non-responsive any Proposal which unevenly weights or allocates costs, including but not limited to overhead and profit to one or more particular Proposal items.

ARTICLE 29. AWARD PROCESS

Once all Bids are opened and reviewed to determine the lowest responsive and responsible Bidder, the City Council may award the Contract. The apparent successful Bidder should begin to prepare the following documents: (1) the Performance Bond; (2) the Payment Bond; and (3) the required insurance certificates and endorsements. Once the City notifies the Bidder of the award, the Bidder will have ten (10) calendar days from the date of this notification to execute the Contract and supply the City with all of the required documents and certifications. Once the City receives all of the properly drafted and executed documents and certifications from the Bidder, the City will initiate the process to schedule a Pre-Construction Meeting and issue a Notice to Proceed to that Bidder.

ARTICLE 30. EXECUTION OF CONTRACT

As required herein the Bidder to whom an award is made shall execute the Contract in the amount determined by the Contract Documents. The City may require appropriate evidence that the persons executing the Contract are duly empowered to do so. The Contract and bond forms to be executed by the successful Bidder are included within these Contract Documents and shall not be detached.

ARTICLE 31. QUESTIONS

Questions regarding this Notice Inviting Bids may be directed to Maritza Martinez, at mmartinez@coachella.org or (760)501-8111. Any and all inquiries and comments regarding this Proposal must be communicated in writing, unless otherwise instructed by the City. The City may, in its sole discretion, disqualify any Bidder who engages in any prohibited communications.

PROPOSAL FORMS

PROPOSAL ACKNOWLEDGMENT

Bids will be received at the City of Coachella, 53462 Enterprise Way, Coachella, California 92236, until 2:00P.M. Tuesday, October 4, 2022.

CY 2023-26 On-Call Striping Contract CITY PROJECT NO. 083122

NAME OF BIDDER: _____

To the City of Coachella, a municipal corporation, organized under the laws of the State of California, with its principal place of business at 53462 Enterprise Way, Coachella, CA 92236.

- A. In response to the Request for Proposals for the FY 2023-26 On-Call Striping Contract - **City Project No. 083122** and in accordance with the accompanying Instructions to Proposers, the undersigned hereby proposes to the City to furnish all labor, technical and professional services, supervision, materials and equipment, other than materials and equipment specified as furnished by the City, and to perform all operations necessary and required to construct the Project in accordance with the provisions of the Contract Documents and any addenda thereto, and at the prices stated opposite the respective items set forth in the Proposal Schedule.
- B. This Proposal constitutes a firm offer to the City which cannot be withdrawn for 90 days after the date set for opening of Bids, or until a Contract is executed by the City and a third party, whichever is earlier.
- C. The undersigned certifies that it has examined and is fully familiar with all of the provisions of the Contract Documents and any addenda thereto; that it has carefully checked all of the words and figures shown in its Proposal Schedule; that it has carefully reviewed the accuracy of all statements in this Proposal and attachments hereto; and that it understands and agrees that the City will not be responsible for any errors or omissions on the part of the undersigned in preparing this Bid.
- D. If awarded a Contract, the undersigned agrees to execute and deliver to the City within ten (10) calendar days after date of receipt of Notice of Award, a signed Contract and the necessary Performance Bond, Payment Bond, and Certificates of Insurance and Endorsements.
- E. The following Proposal Forms, which have been completed and executed by the undersigned Bidder, are incorporated by this reference and made a part of this Bid:
 - 1. Proposal Schedule
 - 2. Proposal Guarantee in the amount of not less than 10% of the Total Proposal Price.
 - 3. Completed Designation of Subcontractors form.

4. Fully executed Noncollusion Declaration form.
5. Completed Iran Contracting Act Certification form.
6. Completed Public Works Contractor DIR Registration Certification form.
7. Completed Drug-Free Work Place Form
8. Completed Contractor's Certificate Regarding Workers' Compensation form
9. Completed Bidder Information and Experience Form.

F. The undersigned is hereby representing that it is and will be properly licensed both at the time that it submits a Proposal as well as at the time the Contract is awarded, if the Contract is awarded to the undersigned.

1. Individual Contractor. Undersigned certifies that it is now licensed in accordance with the provisions of the Contractor's License Law of the State of California.

License number _____

Expiration date _____

License classification _____

1. Joint Venture. Undersigned certifies that the individual members of the joint venture are now licensed in accordance with the provisions of the Contractor's License Law of the State of California.

Member No. 1

Name _____

License number _____

Expiration date _____

License classification _____

Member No. 2

Name _____

License number _____

Expiration date _____

License classification _____

(If there are more than two members of the joint venture, attach a page for the additional member(s) with the above information.)

The undersigned acknowledges receipt, understanding, and full consideration of the following addenda to the Contract Documents:

Addenda No. _____

[SIGNATURE ON NEXT PAGE]

I hereby certify under penalty of perjury under the laws of the State of California that all of the information submitted in connection with this Proposal and all of the representations made herein are true and correct.

BIDDER:

Bidder's Business Address:

(Company Name)

By _____

(Signature)

(Type or print name)

(Title)

(Where signed) (City, State)

Dated _____, 2022

(corporate seal)

State of Incorporation: _____

(If the Prime Contractor is a corporation, two signatures of corporate officers are required.)

Names and addresses of all partners or joint venturers:

Statement of the authority of signatory to bind Bidder:

PROPOSALFORM

NAME OF BIDDER: _____

The undersigned, hereby declare that we have carefully examined the location of the proposed Work, and have read and examined the Contract Documents, including all plans, specifications, and all addenda, if any, for the following Project:

**FY 2023-26 On-Call Striping Contract
CITY PROJECT NO. 083122**

Unit prices in each and every case represent the true unit price used in preparing the Proposal schedule totals (Proposal Form). Unit prices listed herein include material, installation and appurtenant work as is necessary to have the item complete in place, and operational, meeting the full intent of the plans and specifications. For standard striping, all Unit Costs shall include the labor and materials for installation of reflective markers, when appropriate.

It is understood that the basis of award shall be the lowest total price of the sum of the Base Bid.

We hereby propose to furnish all labor, materials, equipment, tools, transportation, and services, and to discharge all duties and obligations necessary and required to perform and complete the Project for the following TOTAL BID PRICE:

BASE BID					
Item No.	Item Description		Unit	Unit Price (in figures) Dollars	Item Total (in figures) Dollars
1.1	Mobilization	1	LS	\$	\$
1.2	Night Work Mobilization	1	LS	\$	\$
2	Dust Control/Stormwater Best Management Practices (BMP's)	1	LS	\$	\$
3	Traffic Control/Site Protection	1	LS	\$	\$
4.0	Removal Striping, Markings and Reflectors				
4.1	12" Wide Stripe	5,240	LF	\$	\$
4.2	8" Wide Stripe	5,240	LF	\$	\$
4.3	6" Wide Stripe	5,240	LF	\$	\$
4.4	4" Wide Stripe	5,240	LF	\$	\$

BASE BID					
Item No.	Item Description		Unit	Unit Price (in figures) Dollars	Item Total (in figures) Dollars
4.5	Pavement Marking	300	SF	\$	\$
4.6	Yellow Centerline	5,240	LF	\$	\$
4.7	Lane Line	15,840	LF	\$	\$
4.8	Left Edge Line	5,240	LF	\$	\$
4.9	Right Edge Line	5,240	LF	\$	\$
4.10	Median Islands	2,620	LF	\$	\$
4.11	Two-Way Left Turn Lane	2,620	LF	\$	\$
4.12	Bike Lane	5,240	LF	\$	\$
4.13	Bike Lane Intersection Line	5,240	LF	\$	\$
4.14	Centerline Extension	500	LF	\$	\$
4.15	Lane Line Extension	500	LF	\$	\$
5.0	Painting of Striping, Markings and Reflectors				
5.1	12" Wide Stripe	5,240	LF	\$	\$
5.2	8" Wide Stripe	5,240	LF	\$	\$
5.3	6" Wide Stripe	5,240	LF	\$	\$
5.4	4" Wide Stripe	5,240	LF	\$	\$
5.5	Pavement Marking	300	SF	\$	\$
5.6	Yellow Centerline	5,240	LF	\$	\$
5.7	Lane Line	15,840	LF	\$	\$
5.8	Left Edge Line	5,240	LF	\$	\$
5.9	Right Edge Line	5,240	LF	\$	\$

BASE BID					
Item No.	Item Description		Unit	Unit Price (in figures) Dollars	Item Total (in figures) Dollars
5.10	Median Islands	2,620	LF	\$	\$
5.11	Two-Way Left Turn Lane	2,620	LF	\$	\$
5.12	Bike Lane	5,240	LF	\$	\$
5.13	Bike Lane Intersection Line	5,240	LF	\$	\$
5.14	Centerline Extension	500	LF	\$	\$
5.15	Lane Line Extension	500	LF	\$	\$
6.0	Install Green Bike Markings (methyl methacrylate markings/MMAX Paint)	15	SF	\$	\$

Total Amount of Base Bid	\$
---------------------------------	-----------

Grand Total of Base Bid

(Words)

\$

(Figure)

The costs for any Work shown or required in the Contract Documents, but not specifically identified as a line item are to be included in the related line items and no additional compensation shall be due to Contractor for the performance of the Work.

All blank spaces appearing above must be filled in. Failure to fill in any blank spaces may render the Proposal non-responsive. In case of discrepancy between the Unit Price and Item Cost set forth for a unit basis item, the Unit Price shall prevail and be utilized as the basis for determining the lowest responsive, responsible Bidder. However, if the amount set forth as a Unit Price is ambiguous, unintelligible or uncertain for any cause, or is omitted, or is the same amount as the entry in the Item Cost column, then the amount set forth in the Item Cost column for the item shall prevail and shall be divided by the estimated quantity for the item and the price thus obtained shall be the Unit Price.

For purposes of evaluating Bids, the City will correct any apparent errors in the extension of unit prices and any apparent errors in the addition of lump sum and extended prices.

The estimated quantities for Unit Price items are approximate and for purposes of comparing Bids only, and the City makes no representation that the actual quantities of work performed will not vary from the estimates. Final payment shall be determined by the Engineer from measured quantities of work performed based upon the Unit Price. A Contract Quantity Adjustment Change Order will be issued upon the completion of the project to adjust the Contract Quantities and Amounts accordingly.

The undersigned agrees that this Proposal Schedule constitutes a firm offer to the City which cannot be withdrawn for the number of calendar days indicated in the Notice Inviting Bids from and after the Proposal opening, or until a Contract for the Work is fully executed by the City and a third party, whichever is earlier.

If the Contract Documents specify Alternate Proposal items, the City can choose to include any, all, or none of the Alternate Proposal items of Work into the executed Contract. If the City selects any of the Alternate Proposal items, the corresponding Alternate Proposal prices shall be added to or deducted from Base Proposal Price for the Work. The City can award/select Alternate Proposal items at any time(s).

Name of Bidder _____

Signature _____

Name and Title _____

Dated _____

PROPOSALGUARANTEE

PROPOSALBOND

[Note: Not required when other form of Bidder’s Security, e.g. cash, certified check or cashier’s check, accompanies Bid.]

The makers of this bond are, _____, as Principal, and _____, as Surety and are held and firmly bound unto the City of Coachella, a municipal corporation, organized under the laws of the State of California, with its principal place of business at 53462 Enterprise Way, Coachella, California 92236, hereinafter called the City, in the penal sum of TEN PERCENT (10%) OF THE TOTAL PROPOSALPRICE of the Principal submitted to the City for the work described below, for the payment of which sum in lawful money of the United States, well and truly to be made, we bind ourselves, our heirs, executors, administrators, successors and assigns, jointly and severally, firmly by these presents.

THE CONDITION OF THIS OBLIGATION IS SUCH that whereas the Principal has submitted the accompanying Proposal dated _____, 2022, for **FY 2023-26 On-Call Striping Contract Project No. 083122.**

If the Principal does not withdraw its Proposal within the time specified in the Contract Documents; and if the Principal is awarded the Contract and provides all documents to the City as required by the Contract Documents; then this obligation shall be null and void. Otherwise, this bond will remain in full force and effect.

Surety, for value received, hereby stipulates and agrees that no change, extension of time, alteration or addition to the terms of the Contract Documents shall affect its obligation under this bond, and Surety does hereby waive notice of any such changes.

In the event a lawsuit is brought upon this bond by the City and judgment is recovered, the Surety shall pay all litigation expenses incurred by the City in such suit, including reasonable attorneys’ fees, court costs, expert witness fees and expenses.

IN WITNESS WHEREOF, the above-bound parties have executed this instrument under their several seals this _____ day of _____, 2022, the name and corporate seal of each corporation.

(Corporate Seal)

Contractor/ Principal

By _____

Title _____

(Corporate Seal)

Surety

By _____

Attorney-in-Fact

(Attach Attorney-in-Fact Certificate)

Title _____

Notary Acknowledgment

A notary public or other officer completing this certificate verifies only the identity of the individual who signed the document to which this certificate is attached, and not the truthfulness, accuracy, or validity of that document.

STATE OF CALIFORNIA
 COUNTY OF _____

On _____, 2022, before me, _____, Notary Public, personally appeared _____, who proved to me on the basis of satisfactory

Name(s) of Signer(s)

evidence to be the person(s) whose name(s) is/are subscribed to the within instrument and acknowledged to me that he/she/they executed the same in his/her/their authorized capacity(ies), and that by his/her/their signature(s) on the instrument the person(s), or the entity upon behalf of which the person(s) acted, executed the instrument.

I certify under PENALTY OF PERJURY under the laws of the State of California that the foregoing paragraph is true and correct.

WITNESS my hand and official seal.

 Signature of Notary Public

OPTIONAL

Though the information below is not required by law, it may prove valuable to persons relying on the document and could prevent fraudulent removal and reattachment of this form to another document.

CAPACITY CLAIMED BY SIGNER

- Individual
- Corporate Officer

Title(s)

- Partner(s)
 - Limited
 - General

- Attorney-In-Fact
- Trustee(s)
- Guardian/Conservator
- Other:

Signer is representing:
 Name Of Person(s) Or Entity(ies)

DESCRIPTION OF ATTACHED DOCUMENT

Title or Type of Document

Number of Pages

Date of Document

Signer(s) Other Than Named Above

NOTE: This acknowledgment is to be completed for Contractor/Principal.

Notary Acknowledgment

A notary public or other officer completing this certificate verifies only the identity of the individual who signed the document to which this certificate is attached, and not the truthfulness, accuracy, or validity of that document.

STATE OF CALIFORNIA
COUNTY OF _____

On _____, 2022, before me, _____, Notary Public, personally appeared _____, who proved to me on the basis of satisfactory

evidence to be the person(s) whose name(s) is/are subscribed to the within instrument and acknowledged to me that he/she/they executed the same in his/her/their authorized capacity(ies), and that by his/her/their signature(s) on the instrument the person(s), or the entity upon behalf of which the person(s) acted, executed the instrument.

I certify under PENALTY OF PERJURY under the laws of the State of California that the foregoing paragraph is true and correct.

WITNESS my hand and official seal.

Signature of Notary Public

OPTIONAL

Though the information below is not required by law, it may prove valuable to persons relying on the document and could prevent fraudulent removal and reattachment of this form to another document.

CAPACITY CLAIMED BY SIGNER

DESCRIPTION OF ATTACHED DOCUMENT

- Individual
- Corporate Officer

Title(s)

Title or Type of Document

- Partner(s) Limited
- General

Number of Pages

- Attorney-In-Fact
- Trustee(s)
- Guardian/Conservator
- Other:

Date of Document

Signer is representing:
Name Of Person(s) Or Entity(ies)

Signer(s) Other Than Named Above

NOTE: This acknowledgment is to be completed for the Attorney-in-Fact. The Power-of-Attorney to local representatives of the bonding company must also be attached.

END OF PROPOSALBOND

DESIGNATION OF SUBCONTRACTORS

The subcontractor listed below will perform work or labor or render service to the contractor in or about the construction of the work or improvement, or are subcontractors licensed by the State of California who will, under subcontract to the contractor, specially fabricate and install a portion of the work or improvement according to detailed drawings contained in the Contract Documents, in an amount in excess of one-half of one percent (1/2 of 1%) of the contractor's total Proposal or \$10,000, whichever is greater. No additional time shall be granted to provide the below requested information.

In compliance with the Subletting and Subcontracting Fair Practices Act Chapter 4 (commencing at Section 4100), Part 1, Division 2 of the California Public Contract Code, the Bidder shall set forth below:

- (a) The portion/percentage of the work to be done by the subcontractor;
- (b) The name and the location of the place of business;
- (c) The California contractor license number; and
- (d) The DIR public works contractor registration number.

If a Bidder fails to specify a subcontractor or if a Bidder specifies more than one subcontractor for the same portion of work, then the Bidder shall be deemed to have agreed that it is fully qualified to perform that portion of work and that it shall perform that portion itself. **If the contractor intends to "Self Perform" all of the work and not utilize any subcontractors, the contractor shall then mark or insert "N/A" on the Subcontractor List form to indicate that the contractor does not intend to utilize any subcontractors to perform any portions of the work. Failure to do so, may deem the Proposal "Non-Responsive".**

% of Work	Name of Subcontractor & Description of the Work	Location of Business	CSLB Contractor License #	DIR Registration Number

% of Work	Name of Subcontractor & Description of the Work	Location of Business	CSLB Contractor License #	DIR Registration Number

(Attach additional sheets if necessary)

Name of Bidder _____

Signature _____

Name and Title _____

Dated _____

BIDDER INFORMATION AND EXPERIENCE FORM

A. INFORMATION ABOUT BIDDER

(Indicate not applicable (“N/A”) where appropriate.)

NOTE: Where Bidder is a joint venture, pages shall be duplicated and information provided for all parties to the joint venture.

1.0 Name of Bidder: _____

2.0 Type, if Entity: _____

3.0 Bidder Address: _____

Facsimile Number

Telephone Number

Email Address

4.0 How many years has Bidder’s organization been in business as a Contractor?

5.0 How many years has Bidder’s organization been in business under its present name? _____

5.1 Under what other or former names has Bidder’s organization operated?

6.0 If Bidder’s organization is a corporation, answer the following:

6.1 Date of Incorporation: _____

6.2 State of Incorporation: _____

6.3 President’s Name: _____

6.4 Vice-President’s Name(s): _____

6.5 Secretary’s Name: _____

6.6 Treasurer’s Name: _____

7.0 If an individual or a partnership, answer the following:

7.1 Date of Organization: _____

7.2 Name and address of all partners (state whether general or limited partnership):

8.0 If other than a corporation or partnership, describe organization and name principals:

9.0 List other states in which Bidder's organization is legally qualified to do business.

10.0 What type of work does the Bidder normally perform with its own forces?

11.0 Has Bidder ever failed to complete any work awarded to it? If so, note when, where, and why:

12.0 Within the last five years, has any officer or partner of Bidder's organization ever been an officer or partner of another organization when it failed to complete a contract? If so, attach a separate sheet of explanation:

13.0 List Trade References:

14.0 List Bank References (Bank and Branch Address):

15.0 Name of Bonding Company and Name and Address of Agent:

[REMAINDER OF THIS PAGE INTENTIONALLY LEFT BLANK]

B. LIST OF CURRENT PROJECTS (BACKLOG)

[**Duplicate Page if needed for listing additional current projects. **]

Project	Client Reference (Agency Name/Contact Info)	Description of Bidder's Work	Completion Date	Cost of Bidder's Work

C. LIST OF COMPLETED PROJECTS – LAST THREE YEARS

[**Duplicate Page if needed for listing additional completed projects. **]

Please include only those projects which are similar enough to demonstrate Bidder's ability to perform the required Work.

Project	Client Reference (Agency Name/Contact Info)	Description of Bidder's Work	Completion Date	Cost of Bidder's Work

D. EXPERIENCE AND TECHNICAL QUALIFICATIONS QUESTIONNAIRE

Personnel:

The Bidder shall identify the key personnel to be assigned to this project in a management, construction supervision or engineering capacity.

1. List each person's job title, name and percent of time to be allocated to this project:

2. Summarize each person's specialized education:

3. List each person's years of construction experience relevant to the project:

4. Summarize such experience:

Bidder agrees that personnel named in this Proposal will remain on this Project until completion of all relevant Work, unless substituted by personnel of equivalent experience and qualifications approved in advance by the City.

E. ADDITIONAL BIDDER'S STATEMENTS:

If the Bidder feels that there is additional information which has not been included in the questionnaire above, and which would contribute to the qualification review, it may add that information in a statement here or on an attached sheet, appropriately marked:

Name of Bidder _____

Signature _____

Name and Title _____

Dated _____

NON-COLLUSION DECLARATION

The undersigned declares:

I am the _____ of _____, the party making the foregoing Bid.

The Proposal is not made in the interest of, or on behalf of, any undisclosed person, partnership, company, association, organization, or corporation. The Proposal is genuine and not collusive or sham. The Bidder has not directly or indirectly induced or solicited any other Bidder to put in a false or sham bid. The Bidder has not directly or indirectly colluded, conspired, connived, or agreed with any Bidder or anyone else to put in a sham bid, or to refrain from bidding. The Bidder has not in any manner, directly or indirectly, sought by agreement, communication, or conference with anyone to fix the Bid Price of the Bidder or any other Bidder, or to fix any overhead, profit, or cost element of the Bid Price, or of that of any other Bidder. All statements contained in the Proposal are true. The Bidder has not, directly or indirectly, submitted his or her Bid Price or any breakdown thereof, or the contents thereof, or divulged information or data relative thereto, to any corporation, partnership, company, association, organization, Proposal depository, or to any member or agent thereof to effectuate a collusive or sham bid, and has not paid, and will not pay, any person or entity for such purpose.

Any person executing this declaration on behalf of a Bidder that is a corporation, partnership, joint venture, limited liability company, limited liability partnership, or any other entity, hereby represents that he or she has full power to execute, and does execute, this declaration on behalf of the Bidder.

I declare under penalty of perjury under the laws of the State of California that the foregoing is true and correct and that this declaration is executed on _____ [date], at _____ [city], _____ [state].

Name of Bidder _____

Signature _____

Name and Title _____

Dated _____

IRAN CONTRACTING ACT CERTIFICATION

(Public Contract Code section 2200 et seq.)

As required by California Public Contract Code Section 2204, the Contractor certifies subject to penalty for perjury that the option checked below relating to the Contractor’s status in regard to the Iran Contracting Act of 2010 (Public Contract Code Section 2200 et seq.) is true and correct:

The Contractor is not:

(1) identified on the current list of person and entities engaged in investment activities in Iran prepared by the California Department of General Services in accordance with subdivision (b) of Public Contract Code Section 2203; or

(2) a financial instruction that extends, for 45 days or more, credit in the amount of \$20,000,000 or more to any other person or entity identified on the current list of persons and entities engaging in investment activities in Iran prepared by the California Department of General Services in accordance with subdivision (b) of Public Contract Code Section 2203, if that person or entity uses or will use the credit to provide goods or services in the energy sector in Iran.

The City has exempted the Contractor from the requirements of the Iran Contracting Act of 2010 after making a public finding that, absent the exemption, the City will be unable to obtain the goods and/or services to be provided pursuant to the Contract.

The amount of the Contract payable to the Contractor for the Project does not exceed \$1,000,000.

Signature: _____

Printed Name: _____

Title: _____

Firm Name: _____

Date: _____

Note: In accordance with Public Contract Code Section 2205, false certification of this form shall be reported to the California Attorney General and may result in civil penalties equal to the greater of \$250,000 or twice the Contract amount, termination of the Contract and/or ineligibility to bid on contracts for three years.

ASBESTOS-FREE MATERIALS CERTIFICATION

The undersigned declares that he or she is the person who executed the Proposal for the FY 2023-26 On-Call Striping Contract (hereinafter referred to as the "Project"), and submitted it to the **CITY OF COACHELLA** (hereinafter referred to as the "City") on behalf of _____ (hereinafter referred to as the "Contractor").

To the best of my knowledge, information and belief, in completing the Contractor's Work for the Project, no material furnished, installed or incorporated into the Project will contain, or in itself be composed of, any materials listed by the federal or state EPA or federal or state health agencies as a hazardous material.

Any disputes involving the question of whether or not material installed with asbestos-containing equipment is settled by electron microscopy; the cost of any such tests shall be paid by the Contractor.

All work or materials installed by the Contractor which is found to contain asbestos, or work or material installed with asbestos-containing equipment, will be immediately rejected and this work shall be removed and replaced by the Contractor at no additional cost to the City.

Decontamination and removal of work found to contain asbestos or work installed with asbestos-containing equipment shall be done only under supervision of a qualified consultant, knowledgeable in the field of asbestos abatement and accredited by the Environmental Protection Agency.

The ASBESTOS REMOVAL CONTRACTOR shall be an EPA accredited contractor qualified in the removal of asbestos and shall be chosen and approved by the Asbestos Consultant who shall have sole discretion and final determination in this matter.

The asbestos consultant shall be chosen and approved by the Construction Manager/Architect or the City who shall have sole discretion and final determination in this matter.

The work will be not accepted until asbestos contamination is reduced to levels deemed acceptable by the Asbestos Consultant.

I declare under penalty of perjury under the laws of the State of California that the foregoing is true and correct.

Executed on this _____ day of _____, 2022 at _____.

Name of Contractor (Print or Type)

By _____

Signature

Print Name

Notary Acknowledgment

A notary public or other officer completing this certificate verifies only the identity of the individual who signed the document to which this certificate is attached, and not the truthfulness, accuracy, or validity of that document.

STATE OF CALIFORNIA
COUNTY OF _____

On _____, 2022, before me, _____, Notary Public, personally appeared _____, who proved to me on the basis of satisfactory

evidence to be the person(s) whose name(s) is/are subscribed to the within instrument and acknowledged to me that he/she/they executed the same in his/her/their authorized capacity(ies), and that by his/her/their signature(s) on the instrument the person(s), or the entity upon behalf of which the person(s) acted, executed the instrument.

I certify under PENALTY OF PERJURY under the laws of the State of California that the foregoing paragraph is true and correct.

WITNESS my hand and official seal.

Signature of Notary Public

OPTIONAL

Though the information below is not required by law, it may prove valuable to persons relying on the document and could prevent fraudulent removal and reattachment of this form to another document.

CAPACITY CLAIMED BY SIGNER

DESCRIPTION OF ATTACHED DOCUMENT

- Individual
- Corporate Officer

_____ Title(s)

_____ Title or Type of Document

- Partner(s) Limited
- General

_____ Number of Pages

- Attorney-In-Fact
- Trustee(s)
- Guardian/Conservator
- Other:

_____ Date of Document

Signer is representing:
Name Of Person(s) Or Entity(ies)

_____ Signer(s) Other Than Named Above

RECYCLED CONTENT CERTIFICATION

The undersigned declares that he or she is the person who executed the Proposal for the _____ (hereinafter referred to as the "Project"), and submitted it to the **CITY OF COACHELLA** (hereinafter referred to as the "City") on behalf of _____ hereinafter referred to as the "Contractor").

Pursuant to Public Contract Code Sections 12205 and 22152, all contractors are required to certify in writing under penalty of perjury the minimum (if not exact) percentage of recycled content in materials, goods, or supplies offered or products used in the performance of their contract, regardless of whether the product meets the required recycled product percentage as defined in Public Contract Code Section 12209. The recycled content shall include both post-consumer material and secondary material as defined in Public Contract Code Section 12200 shall apply.

I declare under penalty of perjury under the laws of the State of California that the following percentages of Post-consumer Material and Secondary Material is in the materials, goods or supplies offered for, or products used in, the performance of the Contract for the Project:

_____ % Post consumer Material _____ % Secondary Material.

Executed on this _____ day of _____, 2022 at _____.

Name of Contractor (Print or Type)

By

Signature

Print Name

Title

Notary Acknowledgment

A notary public or other officer completing this certificate verifies only the identity of the individual who signed the document to which this certificate is attached, and not the truthfulness, accuracy, or validity of that document.

STATE OF CALIFORNIA
COUNTY OF _____

On _____, 2022, before me, _____, Notary Public, personally appeared _____, who proved to me on the basis of satisfactory

evidence to be the person(s) whose name(s) is/are subscribed to the within instrument and acknowledged to me that he/she/they executed the same in his/her/their authorized capacity(ies), and that by his/her/their signature(s) on the instrument the person(s), or the entity upon behalf of which the person(s) acted, executed the instrument.

I certify under PENALTY OF PERJURY under the laws of the State of California that the foregoing paragraph is true and correct.

WITNESS my hand and official seal.

Signature of Notary Public

OPTIONAL

Though the information below is not required by law, it may prove valuable to persons relying on the document and could prevent fraudulent removal and reattachment of this form to another document.

CAPACITY CLAIMED BY SIGNER

- Individual
- Corporate Officer

_____ Title(s)

- Partner(s) Limited General
- Attorney-In-Fact
- Trustee(s)
- Guardian/Conservator
- Other:

Signer is representing:
Name Of Person(s) Or Entity(ies)

DESCRIPTION OF ATTACHED DOCUMENT

_____ Title or Type of Document

_____ Number of Pages

_____ Date of Document

_____ Signer(s) Other Than Named Above

DRUG-FREE WORKPLACE CERTIFICATION

This Drug-Free Workplace Certification form is part of the Contract made by and between the **CITY OF COACHELLA** (hereinafter referred to as the "City") and _____

_____ (hereinafter referred to as the "Contractor") for the _____ Project (hereinafter referred to as the "Project"). This form is required from all successful proposers pursuant to the Drug-Free Workplace Act of 1990 (Government Code Section 8350 et seq.) The Drug-Free Workplace Act of 1990 requires that every person or organization awarded a contract or grant for procurement of any property or service from any State agency must certify that it will provide a drug-free workplace by doing certain specified acts. In addition, the Act provides that each contract or grant awarded by a State agency may be subject to suspension of payments or termination, and the contractor or grantee may be subject to debarment from future contracting, if the contracting agency determines that specified acts have occurred.

Pursuant to Government Code Section 8355, every person or organization awarded a contract or grant from a State agency shall certify that it will provide a drug-free workplace by doing all of the following:

- A. Publishing a statement notifying employees that the unlawful manufacture, distribution, dispensation, possession or use of a controlled substance is prohibited in their workplace and specifying actions which will be taken against employees for violations of the prohibition;
- B. Establishing a drug-free awareness program to inform employees about all of the following:
 - (1) The dangers of drug abuse in the workplace;
 - (2) The person's or organization's policy of maintaining a drug-free workplace;
 - (3) The availability of drug counseling, rehabilitation and employee-assistance programs; and
 - (4) The penalties that may be imposed upon employees for drug abuse violations.
- C. Requiring that each employee engaged in the performance of the contract or grant be given a copy of the statement required by subdivision "A," and that, as a condition of employment on the contract or grant, the employee agrees to abide by the terms of the statement.

I, the undersigned, agree to fulfill the terms and requirements of the Drug-Free Workplace Act as it now exists or may hereinafter be amended. Particularly, I shall abide by Government Code Section 8355 when performing the Contract for the Project by:

- (1). Publishing a statement notifying employees concerning the prohibition of controlled substance at my workplace;

- D. Establishing a drug-free awareness program; and
- E. Requiring that each employee engaged in the performance of the contract be given a copy of the statement required by Section 8355(a) and agree to abide by the terms of that statement.

I also understand that if the City determines that I have either: (a) made a false certification herein; or (b) violated this certification by failing to carry out the requirements of Section 8355, the Contract awarded herein is subject to termination, suspension of payments, or both. I further understand that if I violate the terms of the Drug-Free Workplace Act of 1990, I may be subject to debarment in accordance with the requirements of the Act.

I acknowledge that I am aware of the provisions of Government Code Section 8350 et seq., and hereby certify that I will adhere to the requirements of the Drug-Free Workplace Act of 1990.

Executed on this _____ day of _____,
2022 at _____.

Name of Contractor (Print or Type)

By _____
Signature

Print Name

Title

Notary Acknowledgment

A notary public or other officer completing this certificate verifies only the identity of the individual who signed the document to which this certificate is attached, and not the truthfulness, accuracy, or validity of that document.

STATE OF CALIFORNIA
 COUNTY OF _____

On _____, 2022, before me, _____, Notary Public, personally appeared _____, who proved to me on the basis of satisfactory

evidence to be the person(s) whose name(s) is/are subscribed to the within instrument and acknowledged to me that he/she/they executed the same in his/her/their authorized capacity(ies), and that by his/her/their signature(s) on the instrument the person(s), or the entity upon behalf of which the person(s) acted, executed the instrument.

I certify under PENALTY OF PERJURY under the laws of the State of California that the foregoing paragraph is true and correct.

WITNESS my hand and official seal.

Signature of Notary Public _____

OPTIONAL

Though the information below is not required by law, it may prove valuable to persons relying on the document and could prevent fraudulent removal and reattachment of this form to another document.

CAPACITY CLAIMED BY SIGNER

- Individual
- Corporate Officer

_____ Title(s)

- Partner(s) Limited
- General

- Attorney-In-Fact
- Trustee(s)
- Guardian/Conservator
- Other:

Signer is representing:
 Name Of Person(s) Or Entity(ies)

DESCRIPTION OF ATTACHED DOCUMENT

_____ Title or Type of Document

_____ Number of Pages

_____ Date of Document

_____ Signer(s) Other Than Named Above

PUBLIC WORKS CONTRACTOR REGISTRATION CERTIFICATION

Pursuant to Labor Code sections 1725.5 and 1771.1, all contractors and subcontractors that wish to bid on, be listed in a bid proposal, or enter into a contract to perform public work must be registered with the Department of Industrial Relations. See <http://www.dir.ca.gov/Public-Works/PublicWorks.html> for additional information.

No Proposal will be accepted nor any contract entered into without proof of the contractor's and subcontractors' current registration with the Department of Industrial Relations to perform public work.

Bidder hereby certifies that it is aware of the registration requirements set forth in Labor Code sections 1725.5 and 1771.1 and is currently registered as a contractor with the Department of Industrial Relations.¹

Name of Bidder: _____

DIR Registration Number: _____

DIR Registration Expiration: _____

Small Project Exemption: _____ Yes or _____ No

Unless Bidder is exempt pursuant to the small project exemption, Bidder further acknowledges:

1. Bidder shall maintain a current DIR registration for the duration of the project.
2. Bidder shall include the requirements of Labor Code sections 1725.5 and 1771.1 in its contract with subcontractors and ensure that all subcontractors are registered at the time of Bid opening and maintain registration status for the duration of the project.
3. Failure to submit this form or comply with any of the above requirements may result in a finding that the Proposal is Non-Responsive.

Name of Bidder _____

Signature _____

Name and Title _____

Dated _____

CONTRACTOR'S CERTIFICATE REGARDING WORKERS' COMPENSATION.

I am aware of the provisions of section 3700 of the Labor Code which require every employer to be insured against liability for workers' compensation or to undertake self-insurance in accordance with the provisions of that code, and I will comply with such provisions before commencing the performance of the work of this Contract.

Name of Bidder _____

Signature _____

Name and Title _____

Dated _____

CONTRACTOR AGREEMENT

This Contract for Construction (“Contract”), is made and entered into this ____ day of _____, _____, by and between City of Coachella, a municipal corporation, organized under the laws of the State of California, with its principal place of business at 53462 Enterprise Way, Coachella, California 92236, sometimes hereinafter called the “City” and _____, sometimes hereinafter called “Contractor.”

WITNESSETH: That the parties hereto have mutually covenanted and agreed, and by these presents do covenant and agree with each other as follows:

ARTICLE 1. SCOPE OF WORK.

The Contractor shall perform all Work within the time stipulated in the Contract, and shall provide all labor, materials, equipment, tools, utility services, and transportation to complete all of the Work required in strict compliance with the Contract Documents as specified in Article 5, below, for the following Project:

**FY 2023-26 On-Call Striping Contract
CITY PROJECT NO. 083122**

Contractor is an independent contractor and not an agent of the City. The Contractor and its surety shall be liable to the City for any damages arising as a result of the Contractor’s failure to comply with this obligation.

ARTICLE 2. TERM.

The term of this Agreement shall commence on the _____ day of _____ 2022, and shall terminate on the ____ day of _____ 2023, unless terminated earlier as set forth herein.

This Agreement may be mutually extended for up to two additional one year terms, upon satisfactory performance of all aspects of this Agreement. The City may submit written notice that the Agreement is to be extended at the same terms and compensation as the existing Agreement.

Contractor and City agree that time is of the essence regarding the performance of this Agreement. All work called for under this Agreement will require the Contractor submit and City approve a Project Schedule for completion of work requested.

ARTICLE 3. CONTRACT PRICE.

The City shall pay to the Contractor as full compensation for the performance of the Contract, subject to any additions or deductions as provided in the Contract Documents, and including all applicable taxes and costs, the sum of _____ **Dollars** (\$_____). Payment shall be made as set forth in the General Conditions. The City will pay to Contractor compensation based upon the prices set forth in the Proposal Schedule.

ARTICLE 4. LIQUIDATED DAMAGES.

Contractor acknowledges that the City will sustain actual damages for each and every Working Day completion of the Project is delayed beyond the Contract Time (per approved Project Schedule). Because of the nature of the Project, it would be impracticable or extremely difficult to determine the City's actual damages. Accordingly, in accordance with Government Code section 53069.85, it is agreed that the Contractor will pay the City the sum of **\$500.00** for each and every Working Day of delay beyond the time prescribed in the Contract Documents. In the event this is not paid, the Contractor agrees the City may deduct that amount from any money due or that may become due the Contractor under the Contract. This Section does not exclude recovery of other damages specified in the Contract Documents. Liquidated damages may be deducted from progress payments due Contractor, Project retention or may be collected directly from Contractor, or from Contractor's surety. These provisions for liquidated damages shall not prevent the City, in case of Contractor's default, from terminating the Contractor.

ARTICLE 5. COMPONENT PARTS OF THE CONTRACT.

The "Contract Documents" include the following:

- Notice Inviting Bids
- Instructions to Proposers
- ProposalForms
- ProposalAcknowledgement
- ProposalSchedule
- ProposalGuarantee
- Designation of Subcontractors
- Information Required of Proposers
- Non-Collusion Declaration Form
- Iran Contracting Act Certification
- Drug-Free Workplace Certification
- Asbestos-Free Material Certification
- Recycled Content Certification
- Public Works Contractor DIR Registration Certification
- Performance Bond
- Payment (Labor and Materials) Bond
- Contract for Construction
- General Conditions
- Special Conditions
- Technical Specifications
- Addenda
- Construction Plans and Drawings
- City of Coachella Standard Specifications and Procedures (June 2007)
- City of Coachella Standard Infrastructure Drawings (2007 Edition) including Surface Improvement Standards and Water Standards
- Standard Specifications for Public Works Construction "Greenbook" (2018), Except Sections 1-9
- Standard Plans for Public Works Construction "Greenbook" (2018)
- Caltrans Standard Specifications (2018), except Division 1
- Caltrans Standard Plans (2018)
- Applicable Local Agency Standards and Specifications, as last revised
- Reference Specifications

Approved and fully executed Change Orders
Permits
Any other documents contained in or incorporated into the Contract

The Contractor shall complete the Work in strict accordance with all of the Contract Documents.

All of the Contract Documents are intended to be complementary. Work required by one of the Contract Documents and not by others shall be done as if required by all. In the event of conflict, the various Contract Documents will be given effect in the order set forth in the General Conditions. This Contract shall supersede any prior agreement of the parties.

ARTICLE 6. PROVISIONS REQUIRED BY LAW AND CONTRACTOR COMPLIANCE.

Each and every provision of law required to be included in these Contract Documents shall be deemed to be included in these Contract Documents. The Contractor shall comply with all requirements of applicable federal, state and local laws, rules and regulations, including, but not limited to, the provisions of the California Labor Code and California Public Contract Code which are applicable to this Work.

ARTICLE 7. INDEMNIFICATION.

Contractor shall provide indemnification and defense as set forth in the General Conditions.

ARTICLE 8. PREVAILING WAGES.

Contractor shall be required to pay the prevailing rate of wages in accordance with the Labor Code which such rates may be obtained online at <http://www.dir.ca.gov> and which must be posted at the job site.

ARTICLE 9. FALSE CLAIMS.

Contractor acknowledges that if a false claim is submitted to the City, it may be considered fraud and Contractor may be subject to criminal prosecution. Contractor acknowledges that the False Claims Act, California Government Code sections 12650, et seq., provides for civil penalties where a person knowingly submits a false claim to a public entity. These provisions include within their scope false claims made with deliberate ignorance of the false information or in reckless disregard of the truth or falsity of the information. In the event the City seeks to recover penalties pursuant to the False Claims Act, it is entitled to recover its litigation costs, including attorneys' fees. Contractor hereby acknowledges that the filing of a false claim may the Contractor to an administrative debarment proceeding wherein Contractor may be prevented from further bidding on public contracts for a period of up to five (5) years.

[REMAINDER OF PAGE LEFT INTENTIONALLY BLANK]

IN WITNESS WHEREOF, this Contract has been duly executed by the above-named parties, on the day and year above written.

CITY OF COACHELLA

INSERT CONTRACTOR'S NAME

By: _____
Dr. Gabriel Martin
City Manager

IF CORPORATION, TWO SIGNATURES,
PRESIDENT **OR** VICE PRESIDENT **AND**
SECRETARY **OR** TREASURER **REQUIRED**

By: _____

ATTEST:

Its: _____

By: _____
Andrea Carranza, City Clerk

Printed
Name: _____

APPROVED AS TO FORM:

By: _____

Its: _____

By: _____
Best Best & Krieger LLP
City Attorney

Printed
Name: _____

Contractor's License Number and
Classification

DIR Registration Number

**(CONTRACTOR'S SIGNATURE MUST BE
NOTARIZED AND CORPORATE
SEAL AFFIXED, IF APPLICABLE)**

END OF CONTRACT

Notary Acknowledgment

A notary public or other officer completing this certificate verifies only the identity of the individual who signed the document to which this certificate is attached, and not the truthfulness, accuracy, or validity of that document.

STATE OF CALIFORNIA
COUNTY OF _____

On _____, 2022, before me, _____, Notary Public, personally appeared _____, who proved to me on the basis of satisfactory

evidence to be the person(s) whose name(s) is/are subscribed to the within instrument and acknowledged to me that he/she/they executed the same in his/her/their authorized capacity(ies), and that by his/her/their signature(s) on the instrument the person(s), or the entity upon behalf of which the person(s) acted, executed the instrument.

I certify under PENALTY OF PERJURY under the laws of the State of California that the foregoing paragraph is true and correct.

WITNESS my hand and official seal.

Signature of Notary Public

OPTIONAL

Though the information below is not required by law, it may prove valuable to persons relying on the document and could prevent fraudulent removal and reattachment of this form to another document.

CAPACITY CLAIMED BY SIGNER

- Individual
- Corporate Officer

Title(s)

- Partner(s) Limited General
- Attorney-In-Fact
- Trustee(s)
- Guardian/Conservator
- Other:

Signer is representing:
Name Of Person(s) Or Entity(ies)

DESCRIPTION OF ATTACHED DOCUMENT

Title or Type of Document

Number of Pages

Date of Document

Signer(s) Other Than Named Above

BOND FORMS

Performance Bond

KNOW ALL PERSONS BY THESE PRESENTS:

THAT WHEREAS, the City of Coachella, a municipal corporation, organized under the laws of the State of California, with its principal place of business at 53990 Enterprise Way, California 92236, (hereinafter referred to as the "City") has awarded to _____, (hereinafter referred to as the "Contractor") an agreement for **FY 2023-26 On-Call Striping Contract, City Project No. 083122**, (hereinafter referred to as the "Project").

WHEREAS, the work to be performed by the Contractor is more particularly set forth in the Contract Documents for the Project dated _____, (hereinafter referred to as "Contract Documents"), the terms and conditions of which are expressly incorporated herein by reference; and

WHEREAS, the Contractor is required by said Contract Documents to perform the terms thereof and to furnish a bond for the faithful performance of said Contract Documents.

NOW, THEREFORE, we, _____, the undersigned Contractor and _____ as Surety, a corporation organized and duly authorized to transact business under the laws of the State of California, are held and firmly bound unto the City in the sum of _____ **DOLLARS, (\$_____)**, said sum being not less than one hundred percent (100%) of the total amount of the Contract, for which amount well and truly to be made, we bind ourselves, our heirs, executors and administrators, successors and assigns, jointly and severally, firmly by these presents.

THE CONDITION OF THIS OBLIGATION IS SUCH, that, if the Contractor, his or its heirs, executors, administrators, successors or assigns, shall in all things stand to and abide by, and well and truly keep and perform the covenants, conditions and agreements in the Contract Documents and any alteration thereof made as therein provided, on its part, to be kept and performed at the time and in the manner therein specified, and in all respects according to their intent and meaning; and shall faithfully fulfill all obligations including the one (1) year guarantee of all materials and workmanship; and shall indemnify and save harmless the City, its officials, officers, employees, and authorized volunteers, as stipulated in said Contract Documents, then this obligation shall become null and void; otherwise it shall be and remain in full force and effect.

As a part of the obligation secured hereby and in addition to the face amount specified therefore, there shall be included costs and reasonable expenses and fees including reasonable attorney's fees, incurred by the City in enforcing such obligation.

As a condition precedent to the satisfactory completion of the Contract Documents, unless otherwise provided for in the Contract Documents, the above obligation shall hold good for a period of one (1) year after the acceptance of the work by the City, during which time if Contractor shall fail to make full, complete, and satisfactory repair and replacements and totally protect the City from loss or damage resulting from or caused by defective materials or faulty workmanship. The obligations of Surety hereunder shall continue so long as any obligation of Contractor remains. Nothing herein shall limit the City's rights or the Contractor or Surety's obligations under

the Contract, law or equity, including, but not limited to, California Code of Civil Procedure Section 337.15.

Whenever Contractor shall be, and is declared by the City to be, in default under the Contract Documents, the Surety shall remedy the default pursuant to the Contract Documents, or shall promptly, at the City's option:

- i. Take over and complete the Project in accordance with all terms and conditions in the Contract Documents; or
- ii. Obtain a Proposal or bids for completing the Project in accordance with all terms and conditions in the Contract Documents and upon determination by Surety of the lowest responsive and responsible bidder, arrange for a Contract between such bidder, the Surety and the City, and make available as work progresses sufficient funds to pay the cost of completion of the Project, less the balance of the contract price, including other costs and damages for which Surety may be liable. The term "balance of the contract price" as used in this paragraph shall mean the total amount payable to Contractor by the City under the Contract and any modification thereto, less any amount previously paid by the City to the Contractor and any other set offs pursuant to the Contract Documents.
- iii. Permit the City to complete the Project in any manner consistent with California law and make available as work progresses sufficient funds to pay the cost of completion of the Project, less the balance of the contract price, including other costs and damages for which Surety may be liable. The term "balance of the contract price" as used in this paragraph shall mean the total amount payable to Contractor by the City under the Contract and any modification thereto, less any amount previously paid by the City to the Contractor and any other set offs pursuant to the Contract Documents.

Surety expressly agrees that the City may reject any contractor or subcontractor which may be proposed by Surety in fulfillment of its obligations in the event of default by the Contractor.

Surety shall not utilize Contractor in completing the Project nor shall Surety accept a Proposal from Contractor for completion of the Project if the City, when declaring the Contractor in default, notifies Surety of the City's objection to Contractor's further participation in the completion of the Project.

The Surety, for value received, hereby stipulates and agrees that no change, extension of time, alteration or addition to the terms of the Contract Documents or to the Project to be performed thereunder shall in any way affect its obligations on this bond, and it does hereby waive notice of any such change, extension of time, alteration or addition to the terms of the Contract Documents or to the Project.

[REMAINDER OF PAGE LEFT INTENTIONALLY BLANK]

IN WITNESS WHEREOF, we have hereunto set our hands and seals this _____ day of _____, 2022.

(Corporate Seal)

Contractor/ Principal

By _____

Title _____

(Corporate Seal)

Surety

By _____
Attorney-in-Fact

(Attach Attorney-in-Fact Certificate)

Title _____

The rate of premium on this bond is _____ per thousand. The total amount of premium charges is \$_____.
(The above must be filled in by corporate attorney.)

THIS IS A REQUIRED FORM

Any claims under this bond may be addressed to:

(Name and Address of Surety)

(Name and Address of Agent or Representative for service of process in California, if different from above)

(Telephone number of Surety and Agent or Representative for service of process in California)

Notary Acknowledgment

A notary public or other officer completing this certificate verifies only the identity of the individual who signed the document to which this certificate is attached, and not the truthfulness, accuracy, or validity of that document.

STATE OF CALIFORNIA
COUNTY OF _____

On _____, 2022, before me, _____, Notary Public, personally appeared _____, who proved to me on the basis of satisfactory

evidence to be the person(s) whose name(s) is/are subscribed to the within instrument and acknowledged to me that he/she/they executed the same in his/her/their authorized capacity(ies), and that by his/her/their signature(s) on the instrument the person(s), or the entity upon behalf of which the person(s) acted, executed the instrument.

I certify under PENALTY OF PERJURY under the laws of the State of California that the foregoing paragraph is true and correct.

WITNESS my hand and official seal.

Signature of Notary Public

OPTIONAL

Though the information below is not required by law, it may prove valuable to persons relying on the document and could prevent fraudulent removal and reattachment of this form to another document.

CAPACITY CLAIMED BY SIGNER

DESCRIPTION OF ATTACHED DOCUMENT

- Individual
- Corporate Officer

Title(s)

Title or Type of Document

- Partner(s) Limited
- General

Number of Pages

- Attorney-In-Fact
- Trustee(s)
- Guardian/Conservator
- Other:

Date of Document

Signer is representing:
Name Of Person(s) Or Entity(ies)

Signer(s) Other Than Named Above

NOTE: This acknowledgment is to be completed for Contractor/Principal.

Notary Acknowledgment

A notary public or other officer completing this certificate verifies only the identity of the individual who signed the document to which this certificate is attached, and not the truthfulness, accuracy, or validity of that document.

STATE OF CALIFORNIA
COUNTY OF _____

On _____, 2022, before me, _____, Notary Public, personally appeared _____, who proved to me on the basis of satisfactory

evidence to be the person(s) whose name(s) is/are subscribed to the within instrument and acknowledged to me that he/she/they executed the same in his/her/their authorized capacity(ies), and that by his/her/their signature(s) on the instrument the person(s), or the entity upon behalf of which the person(s) acted, executed the instrument.

I certify under PENALTY OF PERJURY under the laws of the State of California that the foregoing paragraph is true and correct.

WITNESS my hand and official seal.

Signature of Notary Public

OPTIONAL

Though the information below is not required by law, it may prove valuable to persons relying on the document and could prevent fraudulent removal and reattachment of this form to another document.

CAPACITY CLAIMED BY SIGNER

- Individual
- Corporate Officer

Title(s)

- Partner(s) Limited
- General

- Attorney-In-Fact
- Trustee(s)
- Guardian/Conservator
- Other:

Signer is representing:
Name Of Person(s) Or Entity(ies)

DESCRIPTION OF ATTACHED DOCUMENT

Title or Type of Document

Number of Pages

Date of Document

Signer(s) Other Than Named Above

NOTE: This acknowledgment is to be completed for the Attorney-in-Fact. The Power-of Attorney to local representatives of the bonding company must also be attached.

END OF PERFORMANCE BOND

Payment Bond (Labor and Materials)

KNOW ALL MEN BY THESE PRESENTS That

WHEREAS, the City of Coachella, a municipal corporation organized and operating under the laws of the State of California (hereinafter designated as the "City"), by action taken or a resolution passed on _____ Date _____, 2022, has awarded to _____ hereinafter designated as the "Principal," a contract for the work described as follows: **FY 2023-26 On-Call Striping Contract, City Project No. 083122** (the "Project"); and

WHEREAS, the work to be performed by the Contractor is more particularly set forth in the Contract Documents for the Project dated _____, (hereinafter referred to as "Contract Documents"), the terms and conditions of which are expressly incorporated herein by reference; and

WHEREAS, said Principal is required to furnish a bond in connection with said contract; providing that if said Principal or any of its Subcontractors shall fail to pay for any materials, provisions, provender, equipment, or other supplies used in, upon, for or about the performance of the work contracted to be done, or for any work or labor done thereon of any kind, or for amounts due under the Unemployment Insurance Code or for any amounts required to be deducted, withheld, and paid over to the Employment Development Department from the wages of employees of said Principal and its Subcontractors with respect to such work or labor the Surety on this bond will pay for the same to the extent hereinafter set forth.

NOW THEREFORE, we, the Principal and _____ as Surety, are held and firmly bound unto the City in the penal sum of _____ **Dollars (\$ _____)** lawful money of the United States of America, for the payment of which sum well and truly to be made, we bind ourselves, our heirs, executors, administrators, successors and assigns, jointly and severally, firmly by these presents.

THE CONDITION OF THIS OBLIGATION IS SUCH that if said Principal, his or its subcontractors, heirs, executors, administrators, successors or assigns, shall fail to pay any of the persons named in Civil Code Section 9100, fail to pay for any materials, provisions or other supplies, used in, upon, for or about the performance of the work contracted to be done, or for any work or labor thereon of any kind, or amounts due under the Unemployment Insurance Code with respect to work or labor performed under the contract, or for any amounts required to be deducted, withheld, and paid over to the Employment Development Department or Franchise Tax Board from the wages of employees of the contractor and his subcontractors pursuant to Revenue and Taxation Code Section 18663, with respect to such work and labor the Surety or Sureties will pay for the same, in an amount not exceeding the sum herein above specified, and also, in case suit is brought upon this bond, all litigation expenses incurred by the City in such suit, including reasonable attorneys' fees, court costs, expert witness fees and investigation expenses.

This bond shall inure to the benefit of any of the persons named in Civil Code Section 9100 so as to give a right of action to such persons or their assigns in any suit brought upon this bond.

It is further stipulated and agreed that the Surety on this bond shall not be exonerated or released from the obligation of this bond by any change, extension of time for performance, addition, alteration or modification in, to, or of any contract, plans, specifications, or agreement pertaining or relating to any scheme or work of improvement herein above described, or pertaining or relating to the furnishing of labor, materials, or equipment therefore, nor by any change or modification of

any terms of payment or extension of the time for any payment pertaining or relating to any scheme or work of improvement herein above described, nor by any rescission or attempted rescission or attempted rescission of the contract, agreement or bond, nor by any conditions precedent or subsequent in the bond attempting to limit the right of recovery of claimants otherwise entitled to recover under any such contract or agreement or under the bond, nor by any fraud practiced by any person other than the claimant seeking to recover on the bond and that this bond be construed most strongly against the Surety and in favor of all persons for whose benefit such bond is given, and under no circumstances shall Surety be released from liability to those for whose benefit such bond has been given, by reason of any breach of contract between the owner or the City and original contractor or on the part of any obligee named in such bond, but the sole conditions of recovery shall be that claimant is a person described in Civil Code Section 9100, and has not been paid the full amount of his claim.

The Surety, for value received, hereby stipulates and agrees that no change, extension of time, alteration or addition to the terms of the Contract to be performed thereunder, shall in any way affect its obligations on this bond, and it does hereby waive notice of any such change, extension of time, alteration or addition to the terms of Contract, including but not limited to, the provisions of Sections 2819 and 2845 of the California Civil Code.

IN WITNESS WHEREOF, we have hereunto set our hands and seals this _____ day of _____, 2022.

(Corporate Seal)

Contractor/ Principal

By _____

Title _____

(Corporate Seal)

Surety

By _____

Attorney-in-Fact

(Attach Attorney-in-Fact Certificate)

Title _____

Notary Acknowledgment

A notary public or other officer completing this certificate verifies only the identity of the individual who signed the document to which this certificate is attached, and not the truthfulness, accuracy, or validity of that document.

STATE OF CALIFORNIA
 COUNTY OF _____

On _____, 2022, before me, _____, Notary Public, personally appeared _____, who proved to me on the basis of satisfactory

evidence to be the person(s) whose name(s) is/are subscribed to the within instrument and acknowledged to me that he/she/they executed the same in his/her/their authorized capacity(ies), and that by his/her/their signature(s) on the instrument the person(s), or the entity upon behalf of which the person(s) acted, executed the instrument.

I certify under PENALTY OF PERJURY under the laws of the State of California that the foregoing paragraph is true and correct.

WITNESS my hand and official seal.

 Signature of Notary Public

OPTIONAL

Though the information below is not required by law, it may prove valuable to persons relying on the document and could prevent fraudulent removal and reattachment of this form to another document.

CAPACITY CLAIMED BY SIGNER

- Individual
- Corporate Officer

_____ Title(s)

- Partner(s) Limited
- General

- Attorney-In-Fact
- Trustee(s)
- Guardian/Conservator
- Other:

Signer is representing:
 Name Of Person(s) Or Entity(ies)

DESCRIPTION OF ATTACHED DOCUMENT

_____ Title or Type of Document

_____ Number of Pages

_____ Date of Document

_____ Signer(s) Other Than Named Above

NOTE: This acknowledgment is to be completed for Contractor/Principal.

Notary Acknowledgment

A notary public or other officer completing this certificate verifies only the identity of the individual who signed the document to which this certificate is attached, and not the truthfulness, accuracy, or validity of that document.

STATE OF CALIFORNIA
 COUNTY OF _____

On _____, 2022, before me, _____, Notary Public, personally appeared _____, who proved to me on the basis of satisfactory

evidence to be the person(s) whose name(s) is/are subscribed to the within instrument and acknowledged to me that he/she/they executed the same in his/her/their authorized capacity(ies), and that by his/her/their signature(s) on the instrument the person(s), or the entity upon behalf of which the person(s) acted, executed the instrument.

I certify under PENALTY OF PERJURY under the laws of the State of California that the foregoing paragraph is true and correct.

WITNESS my hand and official seal.

 Signature of Notary Public

OPTIONAL

Though the information below is not required by law, it may prove valuable to persons relying on the document and could prevent fraudulent removal and reattachment of this form to another document.

CAPACITY CLAIMED BY SIGNER

- Individual
- Corporate Officer

_____ Title(s)

- Partner(s) Limited
- General

- Attorney-In-Fact
- Trustee(s)
- Guardian/Conservator
- Other:

Signer is representing:
 Name Of Person(s) Or Entity(ies)

DESCRIPTION OF ATTACHED DOCUMENT

_____ Title or Type of Document

_____ Number of Pages

_____ Date of Document

_____ Signer(s) Other Than Named Above

NOTE: This acknowledgment is to be completed for the Attorney-in-Fact. The Power-of-Attorney to local representatives of the bonding company must also be attached.

END OF PAYMENT BOND

GENERAL CONDITIONS

ARTICLE 1 - TERMS; DEFINITIONS

1.1 Defined Terms

- A. Whenever used in the Contract Documents and printed with initial capital letters, the terms listed below will have the meanings indicated which are applicable to both the singular and plural thereof. In addition to terms specifically defined below, terms with initial capital letters in the Contract Documents include references to identified articles and paragraphs, and the titles of other documents or forms.
1. Act of God – An earthquake of magnitude of 3.5 or higher on the Richter scale or a tidal wave.
 2. Addenda -- Written or graphic instruments issued prior to the submission of Bids which clarify, correct, or change the Contract Documents.
 3. Additional Work -- New or unforeseen work will be classified as “Additional Work” when the City determines that it is not covered by the Contract.
 4. Applicable Laws -- The laws, statutes, ordinances, rules, codes, regulations, permits, and licenses of any kind, issued by local, state or federal governmental authorities or private authorities with jurisdiction (including utilities), to the extent they apply to the Work.
 5. Proposal-- The offer or proposal of a Bidder submitted on the prescribed form setting forth the prices and other terms for the Work to be performed.
 6. Bid Guarantee -- The Proposal Bond, cashier’s check, or certified check to be made by the Bidder, which is to accompany the Proposal as a guaranty of good faith to enter into a written contract.
 7. Bidder -- The individual or entity who submits a Proposal directly to the City.
 8. Change Order (“CO”) -- A document that authorizes an addition, deletion, or revision in the Work or an adjustment in the Contract Price or the Contract Times, issued on or after the Effective Date of the Contract, in accordance with the Contract Documents and in the form contained in the Contract Documents.
 9. Change Order Request (“COR”) -- A request made by the Contractor for an adjustment in the Contract Price and/or Contract Times as the result of a Contractor-claimed change to the Work. This term may also be referred to as a Change Order Proposal (“COP”), or Request for Change (“RFC”).
 10. City’s Representative – The City of Coachella, and acting through properly authorized agents, such as the Public Works Director or such other agents acting within the scope of the particular duties entrusted to them. Also sometimes referred to as the “City’s

Representative” or “Representative” in the Contract Documents. The terms the City and Owner may be used interchangeably

11. Claim -- A demand or assertion by the City or Contractor seeking an adjustment of Contract Price or Contract Times, or both, or other relief with respect to the terms of the Contract. A demand for money or services by a third party is not a Claim.
12. Contract -- The entire integrated written agreement between the City and Contractor concerning the Work. “Contract” may be used interchangeably with “Agreement” in the Contract Documents. The Contract supersedes prior negotiations, representations, or agreements, whether written or oral, and includes all Contract Documents.
13. Contract Documents -- The documents listed in Section 00 52 13, Article 5 of the Contract for Construction. Some documents provided by the City to the Proposers and Contractor, including but not limited to reports and drawings of subsurface and physical conditions are not Contract Documents.
14. Contract Price -- Amount to be paid by the City to the Contractor as full compensation for the performance of the Contract and completion of the Work, subject to any additions or deductions as provided in the Contract Documents, and including all applicable taxes and costs.
15. Contract Time -- The number of days or the dates stated in the Contract Documents to: achieve defined milestones, if any; and to complete the Work so that it is ready for final payment.
16. Contractor -- The individual or entity with which the City has contracted for performance of the Work.
17. Contractor's Designated On-Site Representative -- The Contractor's Designated On-Site Representative will be identified by the Contractor and shall not be changed without prior written consent of the City.
18. Critical Supply Shortage -- An unusual shortage in materials that is (a) supported by documented proof that Contractor made every effort to obtain such materials from all available sources; (b) such shortage is due to the fact that such materials are not physically available from single or multiple sources or could have been obtained only at exorbitant prices entirely inconsistent with current and standard rates taking into account the quantities involved and the usual industry practices in obtaining such quantities; and (c) such shortages and the difficulties in obtaining alternate sources of materials could not have been known or anticipated by Contractor at the time it submitted its Proposal or entered the Contract. Market fluctuations in prices of materials, whether or not resulting from a Force Majeure Event, does not constitute a Critical Supply Shortage.
19. Day -- A calendar day of 24 hours measured from midnight to the next midnight.
20. Defective Work -- Work that is unsatisfactory, faulty, or deficient; or that does not conform to the Contract Documents; or that does not meet the requirements of any inspection, reference standard, test, or approval referenced in the Contract Documents.

21. Demobilization -- The complete dismantling and removal by the Contractor of all of the Contractor's temporary facilities, equipment, and personnel at the Site.
22. Drawings -- That part of the Contract Documents prepared by of the Engineer of Record which graphically shows the scope, extent, and character of the Work to be performed by Contractor. Shop Drawings and other Contractor Submittals are not Drawings as so defined.
23. Effective Date of the Contract -- The date indicated in the Contract on which it becomes effective, but if no such date is indicated, it means the date on which the Contract is signed and delivered by the last of the two parties to sign and deliver.
24. Engineer -- Whenever not qualified, shall mean the City Engineer or the Engineer authorized to act for and in behalf of the City, acting either directly or through properly authorized agents, such agents acting severally within the scope of the particular duties entrusted to them.
25. Force Majeure Event -- An event that materially affects a party's performance and is one or more of the following: (1) Acts of God or other natural disasters occurring at the Site; (2) terrorism or other acts of a public enemy; (3) orders of governmental authorities (including, without limitation, unreasonable and unforeseeable delay in the issuance of permits or approvals by governmental authorities that are required for the Work); (4) pandemics, epidemics or quarantine restrictions; (5) strikes and other organized labor action occurring at the Site and the effects thereof on the Work, only to the extent such strikes and other organized labor action are beyond the control of Contractor and its Subcontractors, of every Tier, and to the extent the effects thereof cannot be avoided by use of replacement workers; and (6) a Critical Supply Shortage. For purposes of this section, "orders of governmental authorities," includes ordinances, emergency proclamations and orders, rules to protect the public health, welfare and safety, and other actions of the City in its capacity as a municipal authority.
26. Hazardous Waste -- The term "Hazardous Waste" shall have the meaning provided in Section 104 of the Solid Waste Disposal Act (42 U.S.C. § 6903) as amended from time to time, or any substance or material identified as hazardous under any state or federal statute governing handling, disposal and/or cleanup of any such substance or material, whichever is more restrictive.
27. Holiday – 2022/2023 Holidays occur on:
 - Labor Day - Monday September 5
 - Veteran's Day - November 11
 - Thanksgiving Day - Thursday November 24
 - The Day after Thanksgiving- Friday November 25
 - Christmas Eve – Thursday December 22
 - Christmas Day – Monday December 26
 - New Year's Eve – Thursday December 29
 - New Year' Day- Monday January 2
 - Martin Luther King Jr. Day-Monday January 16
 - President's Day- Monday February 20
 - Cesar Chavez Day-Thursday March 30

If any Holiday listed above falls on a Saturday, Saturday and the preceding Friday are both Holidays. If the Holiday should fall on a Sunday, Sunday and the following Monday are both Holidays.

28. Notice of Award -- The written notice by the City to the Successful Bidder stating that upon timely compliance by the Successful Bidder with the conditions precedent listed therein, the City will sign and deliver the Contract.
29. Notice of Completion -- The form which may be executed by the City constituting Final Acceptance of the Project.
30. Notice to Proceed -- A written notice given by the City to Contractor fixing the date on which the Contractor may proceed with the Work and when Contract Times will commence to run.
31. Project -- The total construction of which the Work to be performed under the Contract Documents may be the whole, or a part.
32. Record Drawings -- The record set of as-builts prepared by the Contractor during the Work in accordance with the requirements of the General Conditions.
33. Recyclable Waste Materials -- Materials removed from the Site which are required to be diverted to a recycling center rather than an area landfill. Recyclable Waste Materials include, but are not limited to, asphalt, concrete, brick, concrete block, and rock.
34. Sample -- A physical example furnished by the Contractor to illustrate materials, equipment or workmanship; to establish standards by which the Work will be judged.
35. Schedule of Submittals -- A schedule, prepared and maintained by Contractor, of required submittals and the time requirements to facilitate scheduled performance of related construction activities.
36. Shop Drawings -- All drawings, diagrams, illustrations, schedules, and other data or information which are specifically prepared or assembled by or for Contractor and submitted by Contractor to illustrate some portion of the Work.
37. Site -- Lands or areas indicated in the Contract Documents as being furnished by the City upon which the Work is to be performed, including rights-of-way and easements for access thereto, and such other lands furnished by the City which are designated for the use of Contractor.
38. Stop Payment Notice -- A written notice as defined in Civil Code section 8044.
39. Subcontractor -- An individual or entity other than a Contractor having a contract with any other entity than the City for performance of any portion of the Work at the Site.
40. Submittal -- Written and graphic information and physical samples prepared and supplied by the Contractor demonstrating various portions of the Work.

41. Successful Bidder -- The responsible Bidder submitting a responsive Proposal to whom the City makes an award.
42. Supplier -- A manufacturer, fabricator, supplier, distributor, material man, or vendor having a direct contract with Contractor or with any Subcontractor to furnish materials or equipment used in the performance of the Work or to be incorporated in the Work.
43. Technical Specifications -- That part of the Contract Documents consisting of written requirements for materials, equipment, systems, standards and workmanship as applied to the Work, and certain administrative requirements and procedural matters applicable thereto.
44. Underground Facilities -- All underground pipelines, conduits, ducts, cables, wires, manholes, vaults, tanks, tunnels, or other such facilities or attachments, and any encasements containing such facilities, including those that convey electricity, gases, steam, liquid petroleum products, telephone or other communications, cable television, water, wastewater, storm water, other liquids or chemicals, or traffic or other control systems.
45. Unit Price Work -- Work to be paid for on the basis of unit prices as provided by the Contractor in its Proposal or as adjusted in accordance with the Contract Documents.
46. Warranty -- A guarantee provided to the City by the Contractor that the Work will remain free of defects and suitable for its intended use for the period required by the Contract Documents or the longest period permitted by the law of this state, whichever is longer.
47. Work -- The entire construction or the various separately identifiable parts thereof required to be provided under the Contract Documents. Work includes and is the result of performing or providing all labor, services, and documentation necessary to produce such construction, and furnishing, installing, and incorporating all materials and equipment into such construction, all as required by the Contract Documents.

1.2 Terminology

- A. The words and terms below are not defined but, when used in the Contract Documents, have the indicated meaning.
 1. The word “furnish,” when used in connection with services, materials, or equipment, shall mean to supply and deliver said services, materials, or equipment to the Site (or some other specified location) ready for use or installation and in usable or operable condition.
 2. The word “install,” when used in connection with services, materials, or equipment, shall mean to put into use or place in final position said services, materials, or equipment complete and ready for intended use.
 3. The words “perform” or “provide,” when used in connection with services, materials, or equipment, shall mean to furnish and install said services, materials, or equipment complete and ready for intended use.

4. Regardless of whether “furnish,” “install,” “perform,” or “provide” is used in connection with services, materials, or equipment, an obligation of Contractor is implied.
- B. Unless stated otherwise in the Contract Documents, words or phrases that have a well-known technical or construction industry or trade meaning are used in the Contract Documents in accordance with such recognized meaning.

ARTICLE 2 - PRELIMINARY MATTERS

2.1 Self-Performance

The below shall replace those provisions in Section 3-2 of the Standard Specifications:

The Contractor shall perform, with its own organization, Contract work amounting to at least 50 percent of the Contract Price except that any designated “Specialty Items” may be performed by subcontract and the amount of any such “Specialty Items” so performed will be deducted from the Contract Price before computing the amount required to be performed by the Contractor with its own organization. “Specialty Items” will be identified by the Agency in the Proposal or in the Special Provisions. Where an entire item is subcontracted, the value of work subcontracted will be based on the Contract Unit Price. This will be determined from the information submitted by the Contractor, and subject to approval of the Engineer.

Failure to list subcontractors may render the Proposal nonresponsive and may be grounds for rejection of the bid. Failure to comply with the provisions of the California "Subletting and Subcontracting Fair Practices Act" shall make the Contractor subject to the sanctions as set forth in the Act. Delivery of Contract Documents. **If the contractor intends to “Self Perform” all of the work and not utilize any subcontractors, the contractor shall then mark or insert “N/A” on the Subcontractor List form to indicate that the contractor does not intend to utilize any subcontractors to perform any portions of the work. Failure to do so, may deem the Proposal “Non-Responsive”.**

- A. Within ten (10) Days after receipt of the Notice of Award and before the City will execute the Contract, the Contractor shall furnish and file with the City a signed Contract and the necessary Performance Bond, Payment Bond, and Certificates of Insurance and Endorsements, and submit a Preliminary Schedule, Preliminary Traffic Control Plans, Specified Submittals, as well as any other documents specified in the Contract Documents.

2.2 Bonds

- A. Contractor shall submit the bonds on the forms provided with the Contract Documents, duly executed by a responsible corporate surety admitted to transact surety business in the State of California, as defined in Code of Civil Procedure section 995.120, and listed in the United States Department of the Treasury circular entitled "Companies Holding Certificates of Authority as Acceptable Sureties on Federal Bonds and as Acceptable Reinsuring Companies," authorized to do business in the State of California and acceptable to the City conditioned upon the faithful performance by the Contractor of all requirements of the Contract

Documents. Each of the bonds shall be in a sum no less than one hundred percent (100%) of the Contract Price. Bonds shall be delivered to the City within ten (10) Days after receipt of the Notice of Award and before execution of the Contract by the City.

2.3 Evidence of Insurance

- A. Prior to commencing any Work but no later than ten (10) Days after receipt of the Notice of Award, the Contractor shall submit or cause to be submitted any and all Certificates of Insurance and Endorsements, showing that the Contractor has the required insurance, to the attention of the City. Such insurance is to be provided at the sole cost and expense of the Contractor. No Work shall be performed until all of the required insurance has been received and approved.

2.4 Execution of the Contract

- A. Upon receipt of the required Contract Documents, the City will execute the Contract, establishing the Effective Date of the Contract.

2.5 Contractor's Failure to Perform

- A. Should Contractor fail to comply with timelines provided above, the City shall retain the right to enforce and collect on the Contractor's Bid Guarantee, rescind award to the Contractor and award the Contract to the next lowest responsive, responsible bidder as determined by the City. If the City elects to accept bonds and insurance submitted late, the Contract Times will begin to run as of the date stated in the Notice to Proceed. However, the number of days beyond the original ten (10) Days it took to receive the properly executed Contract and related items may be deducted from the Contract Times.

2.6 Commencement of Contract Times; Notice to Proceed

- A. The City will not issue a Notice to Proceed until after the Effective Date of the Contract. Work shall commence within ten (10) Days of the date stated in the Notice to Proceed. The Contract Time begins to run on the date specified in the Notice to Proceed. No Work shall be done at the Site prior to the issuance of the Notice to Proceed unless otherwise approved by the City.

2.7 Copies of Documents

- A. Contractor will be furnished, free of charge, up to five (5) copies of the Contract Documents. Additional copies may be obtained at cost of reproduction. Contractor shall maintain a clean, undamaged set of Project Plans and Contract Documents, including Submittals, at the Project site unless otherwise approved by the City.

2.8 Substitution Requests, Schedule of Submittals, and Schedule

- A. Substitution Requests. Within thirty-five (35) days of the Award of Contract (unless otherwise approved by the City), Contractor shall provide all substitution requests as further described in the General Conditions.

- B. Schedule of Submittals. Within five (5) Days after the issuance of the Notice of Award (unless otherwise approved by the City), Contractor shall submit to the City a Schedule of Submittals, and plan to provide Preliminary Project Schedules, Traffic Control Plans, and other specified "Submittals" for review and approval prior to the Preconstruction Meeting, and order any long lead time equipment items immediately following the "Notice of Award" and/or City Approval of such items.
- C. Schedule. Within ten (10) days after the issuance of the Notice of Award (unless otherwise approved by the City), the Contractor shall submit a "Preliminary" Construction Schedule. Such schedule shall be reviewed and approved by the City prior to the Preconstruction Meeting and issuance of the Notice to Proceed (NTP).

2.9 Subcontractor Mobilization Meeting.

- A. Prior to the start of each major Subcontractor's Work, the Contractor, the Subcontractor, and City shall attend a "Pre-Start" meeting to discuss the schedule, coordination, procedures, safety, and other administrative issues.

2.10 Authority of Council:

- A. The City Council has the final authority in all matters affecting the Work. Within the scope of the Contract, the City has the authority to enforce compliance with the Contract Documents. The Contractor shall promptly comply with instructions from the City.
- B. The decision of the City is final and binding on all questions relating to:
 - 1. quantities;
 - 2. acceptability of material, equipment, or work;
 - 3. execution, progress or sequence of work;
 - 4. interpretation of the Plans, Specifications, or other Contract Documents; and
 - 5. Any other areas specifically identified in the Contract Documents or under the law.
- C. Compliance with instructions from the City shall be a condition precedent to any payment under the Contract, unless otherwise ordered by the City Council.

2.11 Mobilization

- A. When a Bid item is included in the Bid Schedule for mobilization, the costs of Work in advance of construction operations and not directly attributable to any specific Bid item will be included in the progress estimate. When no Bid item is provided for mobilization, payment for such costs will be deemed to be included in the other items of the Work.

Mobilization shall be paid for at the Contract Lump Sum Price as shown on the Bid Schedule. Fifty percent (50%) of the lump sum price will be paid upon successful move in and completion of mobilization. The remaining fifty percent (50%) shall be paid after the contractor is completely demobilized and all project sites have been satisfactorily restored and the project cleanup is completed.

- B. Payment for mobilization based on the lump sum provided in the Bid Schedule, shall constitute full compensation for all such Work. No payment for mobilization will be made until all of the listed items have been completed to the satisfaction of the Engineer. The scope of the Work included under mobilization shall include, but shall not be limited to, the following principal items:
1. Obtaining and paying for all bonds, insurance, and permits.
 2. Moving on to the Project Site of all Contractor's plant and equipment required for the first month's operations.
 3. Installing temporary construction power, wiring, and lighting facilities, as applicable.
 4. Establishing fire protection system, as applicable.
 5. Developing and installing a construction water supply, as applicable.
 6. Providing on-site sanitary facilities and potable water facilities as specified per Cal-OSHA and these Contract Documents.
 7. Furnishing, installing, and maintaining all storage buildings or sheds required for temporary storage of products, equipment, or materials that have not yet been installed in the Work. All such storage shall meet manufacturer's specified storage requirements, and the specific provisions of the specifications, including temperature and humidity control, if recommended by the manufacturer, and for all security.
 8. Arranging for and erection of Contractor's work and storage yard.
 9. Posting all OSHA required notices and establishment of safety programs per Cal-OSHA.
 10. Full-time presence of Contractor's superintendent at the job Site as required herein.
 11. Submittal of construction schedule as required by the Contract Documents.

ARTICLE 3 - CONTRACT DOCUMENTS; INTENT

3.1 Examination of Drawings, Specifications, and Site of Work

- A. Examination of Contract Documents; Site. Before commencing any portion of the Work, Contractor shall again carefully examine all applicable Contract Documents, the Project Site, and other information given to Contractor as to materials and methods of construction and other Project requirements. Contractor shall immediately notify the Engineer of any potential error, inconsistency, ambiguity, conflict, or lack of detail or explanation. If Contractor performs, permits, or causes the performance of any Work which is in error, inconsistent or ambiguous, or not sufficiently detailed or explained, Contractor shall bear any and all resulting costs, including, without limitation, the cost of correction. In no case shall the Contractor

or any Subcontractor proceed with Work if uncertain as to the applicable requirements.

- B. Additional Instructions. After notification of any error, inconsistency, ambiguity, conflict, or lack of detail or explanation, the Engineer will provide any required additional instructions, by means of drawings or other written direction, necessary for proper execution of Work.
- C. Quality of Parts, Construction and Finish. All parts of the Work shall be new, of the best quality of their respective kinds, and the Contractor must use all diligence to inform itself fully as to the required construction and finish.
- D. Contractor's Variation from Contract Document Requirements. If it is found that the Contractor has varied from the requirements of the Contract Documents including the requirement to comply with all Applicable Laws, the Engineer may at any time, before or after completion of the Work, order the improper Work removed, remade or replaced by the Contractor at the Contractor's expense.

3.2 Intent of Contract Documents

- A. The Contract Documents are complementary; what is required by any one will be binding as if required by all. It is the intent of the Contract Documents to describe a functionally complete Project (or part thereof) to be constructed in accordance with the Contract Documents. Any labor, documentation, services, materials, or equipment that reasonably may be inferred from the Contract Documents or from prevailing custom or trade usage as being required to produce the indicated result will be provided whether or not specifically called for, at no additional cost to the City.
- B. The Contractor shall furnish, unless otherwise provided in the Contract Documents, all materials, implements, machinery, equipment, tools, supplies and labor necessary to the prosecution and completion of a Complete and Operational Project.
- C. Clarifications and interpretations of the Contract Documents shall be issued by the Engineer as provided in these General Conditions.
- D. If utilities to equipment/fixtures are not shown but are necessary to operate the equipment/fixtures, the utilities service installation is considered to be part of the Work. The implied Work will conform to the appropriate sections of the Contract Documents.
- E. Organization of the Contract Documents into divisions, sections, and articles, and arrangement of drawings shall not control the Contractor in dividing Work among Subcontractors or in establishing the extent of Work to be performed by any trade.

3.3 Reference Standards.

- A. Standards, Specifications, Codes, Laws, and Regulations.
 - 1. Reference to federal specifications, federal standards, other standards, specifications, manuals, or codes of any technical society, organization, or association, or to Applicable Laws, whether such reference be specific or by

implication, shall mean the standard, specification, manual, code, or Applicable Laws in effect at the time of opening of Bids (or on the Effective Date of the Contract if there were no Bids), except as may be otherwise specifically stated in the Contract Documents.

2. No provision of any such standard, specification, manual, or code, or any instruction of a Supplier, shall be effective to change the duties or responsibilities of the City, Contractor, or any of their Subcontractors, consultants, agents, or employees, from those set forth in the Contract Documents. No such provision or instruction shall be effective to assign to the City, or any of their officers, directors, members, partners, employees, agents, consultants, or subcontractors, any duty or authority to supervise or direct the performance of the Work or any duty or authority to undertake responsibility inconsistent with the provisions of the Contract Documents.

3.4 Reporting and Resolving Discrepancies; Order of Precedence.

A. Reporting Discrepancies.

1. The Contract Documents are intended to be fully cooperative and complementary. Before undertaking each part of the Work, Contractor shall carefully study and compare the Contract Documents and check and verify pertinent figures therein and all applicable field measurements. Contractor shall promptly report in writing to the City any conflict, error, ambiguity, or discrepancy which Contractor discovers, should have discovered, or has actual knowledge of, and shall obtain a written interpretation or clarification from the City before proceeding with any Work affected thereby. If, during the performance of the Work, Contractor discovers any conflict, error, ambiguity, or discrepancy within the Contract Documents, or between the Contract Documents and (i) any Applicable Law, (ii) any standard, specification, manual, or code, or (iii) any instruction of any Supplier, then Contractor shall promptly submit a written Request for Information (RFI) to the City. Contractor shall not proceed with the Work affected thereby (except in an emergency) until an amendment or supplement to the Contract Documents has been issued by one of the methods indicated in the Contract Documents, and any Work performed by Contractor before receipt of an amendment or supplement shall be at Contractor's own risk.

B. Order of Precedence.

1. In case of conflicts between the Contract Documents, the order of precedence shall be as follows:
 - a. Permits from other agencies as may be required by law
 - b. Change Orders, most recent first
 - c. Contract
 - d. Addenda, most recent first
 - e. Special Conditions

- f. Technical Specifications
 - g. Contract Drawings
 - h. General Conditions
 - i. Instructions to Proposers
 - j. Notice Inviting Bids
 - k. Contractor's Proposal(Proposal Forms)
 - l. City of Coachella Standard Infrastructure Drawings (2007 Edition) including Surface Improvement Standards and Water Standards
 - m. City of Coachella Standard Specifications and Procedures (June 2007)
 - n. Standard Specifications for Public Works Construction "Greenbook" (2021) (Sections 1-9 Excluded)
 - o. Standard Plans for Public Works Construction "Greenbook" (2021)
 - p. Caltrans Standard Specifications (2021), except Division 1
 - q. Caltrans Standard Plans (2021)
 - r. Applicable Local Agency Standards and Specifications
 - s. Standard Drawings
 - t. Reference Documents
2. With reference to the Drawings the order of precedence shall be as follows:
 - a. Figures govern over scaled dimensions
 - b. Detail drawings govern over general drawings
 - c. Addenda/Change Order drawings govern over Drawings
 - d. Contract Drawings govern over Standard Drawings
 - e. Contract Drawings govern over Shop Drawings
 3. Notwithstanding the orders of precedence established above, in the event of conflicts, the higher standard and higher quality shall always apply.

3.5 Amending and Supplementing Contract Documents.

- A. The Contract Documents may be amended to provide for additions, deletions, and revisions in the Work or to modify the terms and conditions thereof only by Change Order or written amendment to the Contract duly executed by the parties.

- B. The requirements of the Contract Documents may be supplemented, and minor variations and deviations in the Work may be authorized at no cost to the City, by one or more of the following ways:
 - 1. The City's review of a Submittal, Shop Drawing, Sample or substitution request without exception (subject to the provisions of the Contract Documents); or
 - 2. The City's issuance of a response to an RFI.
- C. However, no review or RFI response will reduce or modify the Contractor's obligation to fully satisfy and comply with the requirements of the Contract Documents.

3.6 Reuse of Documents.

- A. Contractor and any Subcontractor or Supplier shall not:
 - 1. have or acquire any title to or ownership rights in any of the Drawings, Specifications, or other documents (or copies of any thereof) prepared by or bearing the seal of Engineer of Record or its consultants, including electronic media editions; or
 - 2. reuse any such Drawings, Specifications, other documents, or copies thereof on extensions of the Project or any other project without written consent of the City and Engineer of Record and specific written verification or adaptation by Engineer of Record.
- B. The prohibitions of this Article will survive final payment, or termination of the Contract. Nothing herein shall preclude Contractor from retaining copies of the Contract Documents for record purposes.

ARTICLE 4 - INDEMNIFICATION; INSURANCE

4.1 Indemnification

- A. To the fullest extent permitted by law, Contractor shall immediately defend (with counsel of the City's choosing), indemnify and hold harmless the City, its officials, officers, agents, employees, and representatives, and each of them from and against:
 - 1. Any and all claims, demands, causes of action, costs, expenses, injuries, losses or liabilities, in law or in equity, of every kind or nature whatsoever, but not limited to, injury to or death, including wrongful death, of any person, and damages to or destruction of property of any person, arising out of, related to, or in any manner directly or indirectly connected with the Work or this Contract, including claims made by subcontractors for nonpayment, including without limitation the payment of all consequential damages and attorney's fees and other related costs and expenses, however caused, regardless of whether the allegations are false, fraudulent, or groundless, and regardless of any negligence of the City or its officers, employees, or authorized volunteers (including passive negligence), except the sole negligence or willful misconduct or active negligence of the City or its officials, officers, employees, or authorized volunteers.

2. Contractor's defense and indemnity obligation herein includes, but is not limited to damages, fines, penalties, attorney's fees and costs arising from claims under the Americans with Disabilities Act (ADA) or other federal or state disability access or discrimination laws arising from Contractor's Work during the course of construction of the improvements or after the Work is complete, as the result of defects or negligence in Contractor's construction of the improvements.
 3. Any and all actions, proceedings, damages, costs, expenses, fines, penalties or liabilities, in law or equity, of every kind or nature whatsoever, arising out of, resulting from, or on account of the violation of any governmental law or regulation, compliance with which is the responsibility of Contractor;
 4. Any and all losses, expenses, damages (including damages to the Work itself), attorney's fees, and other costs, including all costs of defense which any of them may incur with respect to the failure, neglect, or refusal of Contractor to faithfully perform the Work and all of Contractor's obligations under Contract. Such costs, expenses, and damages shall include all costs, including attorney's fees, incurred by the indemnified parties in any lawsuit to which they are a party.
- B. Contractor shall immediately defend, at Contractor's own cost, expense and risk, with the counsel of the City choosing, any and all such aforesaid suits, actions or other legal proceedings of every kind that may be brought or instituted against the City, its officials, officers, agents, employees and representatives. Contractor shall pay and satisfy any judgment, award or decree that may be rendered against the City, its officials, officers, employees, agents, employees and representatives, in any such suit, action or other legal proceeding. Contractor shall reimburse the City, its officials, officers, agents, employees and representatives for any and all legal expenses and costs incurred by each of them in connection therewith or in enforcing the indemnity herein provided. The only limitations on this provision shall be those imposed by Civil Code section 2782.
- C. The provisions of this Article shall survive the termination of this Contract howsoever caused, and no payment, partial payment, or acceptance of occupancy in whole or part of the Work shall waive or release any of the provisions of this Article.

4.2 Insurance

The Contractor shall obtain, and at all times during performance of the Work of Contract, maintain all of the insurance described in this Article. Contractor shall not commence Work under this Contract until it has provided evidence satisfactory to the City that it has secured all insurance required hereunder. Contractor shall not allow any Subcontractor to commence work on any subcontract until it has provided evidence satisfactory to the City that the subcontractor has secured all insurance required under this Article. Failure to provide and maintain all required insurance shall be grounds for the City to terminate this Contract for cause. Contractor shall furnish the City with original certificates of insurance and endorsements effective coverage required by this Contract on forms satisfactory to the City. The certificates and endorsements for each insurance policy shall be signed by a person authorized by that insurer to bind coverage on its behalf, and shall be on forms acceptable to the City. All certificates and endorsements must be received and approved by the City before Work commences.

- A. **Additional Insureds; Waiver of Subrogation.** The City, its officials, officers, employees, agents and authorized volunteers shall be named as Additional Insureds on Contractor's All Risk policy and on Contractor's and its subcontractors' policies of Commercial General Liability and Automobile Liability insurance using, for Contractor's policy/ies of Commercial General Liability insurance, ISO CG forms 20 10 and 20 37 (or endorsements providing the exact same coverage, including completed operations), and, for subcontractors' policies of Commercial General Liability insurance, ISO CG form 20 38 (or endorsements providing the exact same coverage). Notwithstanding the minimum limits set forth in this Contract for any type of insurance coverage, all available insurance proceeds in excess of the specified minimum limits of coverage shall be available to the parties required to be named as Additional Insureds hereunder. All insurance coverage maintained or procured pursuant to this Contract shall be endorsed to waive subrogation against the City, its officers, officials, agents, employees or volunteers or shall specifically allow Contractor or others providing insurance evidence in compliance with these specifications - to waive their right of recovery prior to a loss. Contractor hereby waives its own right of recovery against the City, and shall require similar written express waivers and insurance clauses from each of its subcontractors. Copies of these waivers shall be submitted to the City prior to commencement of work.
- B. **Workers' Compensation Insurance.** The Contractor shall provide workers' compensation insurance for all of the employees engaged in Work under this Contract, on or at the Site, and, in case of any sublet Work, the Contractor shall require the subcontractor similarly to provide workers' compensation insurance for all the latter's employees as prescribed by State law. Any class of employee or employees not covered by a subcontractor's insurance shall be covered by the Contractor's insurance. In case any class of employees engaged in work under this Contract, on or at the Site, is not protected under the Workers' Compensation Statutes, the Contractor shall provide or shall cause a subcontractor to provide, adequate insurance coverage for the protection of such employees not otherwise protected. The Contractor is required to secure payment of compensation to his employees in accordance with the provisions of section 3700 of the Labor Code. The Contractor shall file with the City certificates of his insurance protecting workers. Company or companies providing insurance coverage shall be acceptable to the City, if in the form and coverage as set forth in the Contract Documents.
- C. **Employer's Liability Insurance.** Contractor shall provide **Employer's Liability Insurance, including Occupational Disease, in the amount of at least one million dollars (\$1,000,000.00) per person per accident. Contractor shall provide the City with a certificate of Employer's Liability Insurance.** Such insurance shall comply with the provisions of the Contract Documents. The policy shall be endorsed, if applicable, to provide a Borrowed Servant/Alternate Employer Endorsement and contain a Waiver of Subrogation in favor of the City.
- D. **Commercial General Liability Insurance.** Contractor shall provide **"occurrence" form Commercial General Liability insurance coverage at least as broad as the most current ISO CGL Form 00 01, including but not limited to, premises liability, contractual liability, products/completed operations, personal and advertising injury which may arise from or out of Contractor's operations, use, and management of the Site, or the performance of its obligations hereunder.** The policy shall not contain any exclusion contrary to this

Contract including but not limited to endorsements or provisions limiting coverage for (1) contractual liability (including but not limited to ISO CG 24 26 or 21 39); or (2) cross-liability for claims or suits against one insured against another. **Policy limits shall not be less than \$2,000,000 per occurrence for bodily injury, personal injury and property damage.** If Commercial General Liability Insurance or other form with a general aggregate limit is used, either the general aggregate limit shall apply separately to this project/location or the general aggregate limit shall be twice the required occurrence limit. Defense costs shall be paid in addition to the limits.

1. Such policy shall comply with all the requirements of this Article. The limits set forth herein shall apply separately to each insured against whom claims are made or suits are brought, except with respect to the limits of liability. Further the limits set forth herein shall not be construed to relieve the Contractor from liability in excess of such coverage, nor shall it limit Contractor's indemnification obligations to the City, and shall not preclude the City from taking such other actions available to the City under other provisions of the Contract Documents or law.
 2. All general liability policies provided pursuant to the provisions of this Article shall comply with the provisions of the Contract Documents.
 3. All general liability policies shall be written to apply to all bodily injury, including death, property damage, personal injury, owned and non-owned equipment, blanket contractual liability, completed operations liability, explosion, collapse, under-ground excavation, removal of lateral support, and other covered loss, however occasioned, occurring during the policy term, and shall specifically insure the performance by Contractor of that part of the indemnification contained in these General Conditions relating to liability for injury to or death of persons and damage to property.
 4. If the coverage contains one or more aggregate limits, a minimum of 50% of any such aggregate limit must remain available at all times; if over 50% of any aggregate limit has been paid or reserved, the City may require additional coverage to be purchased by Contractor to restore the required limits. Contractor may combine primary, umbrella, and as broad as possible excess liability coverage to achieve the total limits indicated above. Any umbrella or excess liability policy shall include the additional insured endorsement described in the Contract Documents.
 5. All policies of general liability insurance shall permit and Contractor does hereby waive any right of subrogation which any insurer of Contractor may acquire from Contractor by virtue of the payment of any loss.
- E. **Automobile Liability Insurance. Contractor shall provide Automobile Liability Insurance at least as broad as ISO CA 00 01 (Any Auto) in the amount of, at least, one million dollars (\$1,000,000) per accident for bodily injury and property damage.** Such insurance shall provide coverage with respect to the ownership, operation, maintenance, use, loading or unloading of any auto owned, leased, hired or borrowed by Contractor or for which Contractor is responsible, in a form and with insurance companies acceptable to the City. All policies of automobile insurance shall permit and Contractor does hereby waive any right of subrogation

which any insurer of Contractor may acquire from Contractor by virtue of the payment of any loss.

F. Builder's Risk ["All Risk"]

1. It is the Contractor's responsibility to maintain or cause to be maintained Builder's Risk ["All Risk"] extended coverage insurance on all work, material, equipment, appliances, tools, and structures that are or will become part of the Work and subject to loss or damage by fire, and vandalism and malicious mischief, in an amount to cover 100% of the replacement cost. The City accepts no responsibility for the Work until the Work is formally accepted by the City. The Contractor shall provide a certificate evidencing this coverage before commencing performance of the Work.
2. The named insureds shall be Contractor, all Subcontractors of any tier (excluding those solely responsible for design work), suppliers, and the City, its elected officials, officers, employees, agents and authorized volunteers, as their interests may appear. Contractor shall not be required to maintain property insurance for any portion of the Work following acceptance by the City.
3. Policy shall be provided for replacement value on an "all risk" basis. There shall be no coinsurance penalty provision in any such policy. Policy must include: (1) coverage for any ensuing loss from faulty workmanship, nonconforming work, omission or deficiency in design or specifications; (2) coverage against machinery accidents and operational testing; (3) coverage for removal of debris, and insuring the buildings, structures, machinery, equipment, materials, facilities, fixtures and all other properties constituting a part of the Project; (4) transit coverage, including ocean marine coverage (unless insured by the supplier), with sub-limits sufficient to insure the full replacement value of any key equipment item; and (5) coverage with sub-limits sufficient to insure the full replacement value of any property or equipment stored either on or off the Site. Such insurance shall be on a form acceptable to the City to ensure adequacy and sublimit.
4. In addition, the policy shall meet the following requirements:
 - a. Insurance policies shall be so conditioned as to cover the performance of any extra work performed under the Contract.
 - b. Coverage shall include all materials stored on site and in transit.
 - c. Coverage shall include Contractor's tools and equipment.
 - d. Insurance shall include boiler, machinery and material hoist coverage.

G. **Contractor's Pollution Liability Coverage. Contractor shall provide pollution liability insurance in an amount not less than \$1,000,000 per occurrence and \$2,000,000 aggregate.**

- H. Contractor shall require all tiers of Subcontractors working under this Contract to provide the insurance required under this Article unless otherwise agreed to in writing by the City. Contractor shall make certain that any and all Subcontractors

hired by Contractor are insured in accordance with this Contract. If any Subcontractor's coverage does not comply with the foregoing provisions, Contractor shall indemnify and hold the City harmless from any damage, loss, cost, or expense, including attorneys' fees, incurred by the City as a result thereof.

- I. Notwithstanding the minimum limits set forth in this Contract for any type of insurance coverage, if Contractor maintains higher limits than the minimums shown above, the City requires and shall be entitled to coverage for the higher limits maintained by the Contractor. Any available insurance proceeds in excess of the specified minimum limits of insurance and coverage shall be available to the City.

J. Form and Proof of Carriage of Insurance

1. Any insurance carrier providing insurance coverage required by the Contract Documents shall be admitted to and authorized to do business in the State of California unless waived, in writing, by the City's Risk Manager. Carrier(s) shall have an A.M. Best rating of not less than an A:VII. Insurance deductibles or self-insured retentions must be declared by the Contractor. At the election of the City the Contractor shall either 1) reduce or eliminate such deductibles or self-insured retentions, or 2) procure a bond which guarantees payment of losses and related investigations, claims administration, and defense costs and expenses. If umbrella or excess liability coverage is used to meet any required limit(s) specified herein, the Contractor shall provide a "follow form" endorsement satisfactory to the City indicating that such coverage is subject to the same terms and conditions as the underlying liability policy.
2. Each insurance policy required by this Contract shall be endorsed to state that: (1) coverage shall not be suspended, voided, reduced or cancelled except after thirty (30) days prior written notice by certified mail, return receipt requested, has been given to the City; and (2) any failure to comply with reporting or other provisions of the policies, including breaches of warranties, shall not affect coverage provided to the City, its officials, officers, agents, employees, and volunteers.
3. The Certificates(s) and policies of insurance shall contain or shall be endorsed to contain the covenant of the insurance carrier(s) that it shall provide no less than thirty (30) days written notice be given to the City prior to any material modification or cancellation of such insurance. In the event of a material modification or cancellation of coverage, the City may terminate the Contract or stop the Work in accordance with the Contract Documents, unless the City receives, prior to such effective date, another properly executed original Certificate of Insurance and original copies of endorsements or certified original policies, including all endorsements and attachments thereto evidencing coverage's set forth herein and the insurance required herein is in full force and effect. Contractor shall not take possession, or use the Site, or commence operations under this Contract until the City has been furnished original Certificate(s) of Insurance and certified original copies of endorsements or policies of insurance including all endorsements and any and all other attachments as required in this Article. The original endorsements for each policy and the Certificate of Insurance shall be signed by an individual authorized by the insurance carrier to do so on its behalf.

4. The Certificate(s) of Insurance, policies and endorsements shall so covenant and shall be construed as primary, and the City's insurance and/or deductibles and/or self-insured retentions or self-insured programs shall not be construed as contributory.
5. The City reserves the right to adjust the monetary limits and types of insurance coverages during the term of this Contract including any extension thereof if, in the City's reasonable judgment, the amount or type of insurance carried by the Contractor becomes inadequate.
6. Contractor shall report to the City, in addition to the Contractor's insurer, any and all insurance claims submitted by the Contractor in connection with the Work under this Contract.
7. Products/completed operations coverage shall extend a minimum of three years after the project completion. Coverage shall be included on behalf of the insured for covered claims arising out of the actions of independent contractors. If the insured is using subcontractors, the policy must include work performed "by or on behalf" of the insured. Policy shall contain no language that would invalidate or remove the insurer's duty to defend or indemnify for claims or suits expressly excluded from coverage. Policy shall specifically provide for a duty to defend on the part of the insurer. The City, its officers, officials, agents employees, and volunteers shall be included as insureds under the policy.

ARTICLE 5 - CONTRACTOR RESPONSIBILITIES; REGULATORY REQUIREMENTS

5.1 Applicable Laws

- A. Contractor shall give all notices required by and shall comply with all Applicable Laws applicable to the performance of the Work. Except where otherwise expressly required by Applicable Laws, neither the City nor the City's Representative shall be responsible for monitoring Contractor's compliance with any Applicable Laws. If Contractor performs any Work knowing or having reason to know that it is contrary to Applicable Laws, Contractor shall bear all claims, costs, losses, and damages (including but not limited to all fees and charges of engineers, architects, attorneys, and other professionals and all court or arbitration or other dispute resolution costs) arising out of or relating to such Work.

5.2 Permits and Licenses

- A. Permits and licenses necessary for prosecution of the Work shall be secured and paid for by Contractor, including, but not limited to, excavation permit, for plumbing, mechanical and electrical work and for operations in or over public streets or right of way under jurisdiction of public agencies other than the City, unless otherwise specified in the Contract Documents.
- B. The Contractor shall arrange and pay for all off-site inspection of the Work related to permits and licenses, including certification, required by the specifications, drawings, or by governing authorities, except for such off-site inspections delineated as the City's responsibility pursuant to the Contract Documents.

- C. Before acceptance of the Work, the Contractor shall submit all licenses, permits, certificates of inspection and required approvals to the City.

5.3 Taxes

- A. Contractor shall pay all sales, consumer, use, and other similar taxes required to be paid in accordance with the Applicable Laws of the place of the Project which are applicable during the performance of the Work. In accordance with Revenue and Taxation Code section 107.6, the Contract Documents may create a possessory interest subject to personal property taxation for which Contractor will be responsible.

5.4 Traffic Control

- A. Traffic Control/Site Protection Plans, shall be prepared at Contractor's expense. Traffic control & Site Protection shall be performed at Contractor's expense in accordance with the requirements of the City and/or the local agency with jurisdiction. Costs for Traffic Control & Site Protection plans, implementation of traffic control and site protection required by the City shall be included in the Contractor's Bid.
- B. All warning signs and safety devices used by the Contractor to perform the Work shall conform to the requirements contained in the State of California, Department of Transportation's current edition of "Manual of Traffic Controls for Construction and Maintenance Work Zones" or to the requirements of the local agency. The Contractor shall also be responsible for all traffic control and site protection required by the agency having jurisdiction over the Project and the intersecting streets. Contractor must submit a Traffic Control and Site Protection plan to the City for approval prior to starting Work. **All barricades utilized for night work, long term, or 24-hour closures, shall be equipped with a flashing beacon and shall be maintained in an operational condition at all times.** Traffic Control and Site Protection Devices and Procedures shall be to the satisfaction of the City.
- C. The Contractor's representative on the site responsible for traffic control/site protection shall produce evidence that he/she has completed training acceptable to the California Department of Transportation for safety through construction zones. Where or when applicable, all adjacent streets in which the Work will occur shall remain open to traffic and two lanes of traffic maintained at all times unless otherwise directed or approved by the agency of jurisdiction. Unless otherwise approved by the City, **businesses and residences adjacent to the Work shall be notified seventy-two (72) hours in advance of closing of any roads or driveways.** The Contractor shall make every effort to minimize the amount of public parking temporarily eliminated due to construction in areas fronting businesses. **No stockpiles of materials will be allowed in traveled right-of-ways after working hours unless otherwise approved by the City.** All stored or stockpiled materials in the Parking Lot, Roadway, or Right of Way shall be moved out of such areas as quickly as possible before spreading or distributing on site to minimize the impact on the traveling public and the citizens. **All storage of materials and clean-up of stored materials shall be to the satisfaction of the City.**

5.5 Safety

- A. Contractor shall be solely responsible for all safety precautions and programs in connection with the Work. Such responsibility does not relieve Subcontractors of their responsibility for the safety of persons or property in the performance of their work, nor for compliance with applicable safety laws. Contractor shall comply with all Applicable Laws relating to the safety of persons or property, or to the protection of persons or property from damage, injury, or loss; and shall erect and properly maintain all necessary safeguards for such safety and protection. Contractor shall notify owners of adjacent property and of Underground Facilities and other utility owners when prosecution of the Work may affect them, and shall cooperate with them in the protection, removal, relocation, and replacement of their property.
- B. The Contractor shall maintain emergency first aid treatment for his employees which complies with the Federal Occupational Safety and Health Act of 1970 (29 U.S.C. § 651 *et seq.*), and California Code of Regulations, Title 8, Industrial Relations Division 1, Department of Industrial Relations, Chapter 4. The Contractor shall ensure the availability of emergency medical services for its employees in accordance with California Code of Regulations, Title 8, Section 1512. The Contractor shall submit an Illness and Injury Prevention Program and a Project Site specific safety program to the City prior to beginning Work. Contractor shall maintain a confined space program that meets or exceeds the City's standards. Contractor needs to make themselves aware of the City's safety policies and procedures and shall meet or exceed all City standards in areas where the City must enter to perform inspections.
- C. Hazard Communication Programs. Contractor shall be responsible for coordinating any exchange of material safety data sheets or other hazard communication information required to be made available to or exchanged between or among employers at the Site in accordance with Applicable Laws.

5.6 Hazardous Materials

- A. The City shall not be responsible for any Hazardous Waste brought to the site by the Contractor. If the Contractor: (i) introduces and/or discharges a Hazardous Waste onto the site in a manner not specified by the Contract Documents; and/or (ii) disturbs a Hazardous Material identified in the Contract Documents, the Contractor shall hire a qualified remediation contractor at Contractor's sole cost to eliminate the condition as soon as possible. Under no circumstance shall the Contractor perform Work for which it is not qualified. The City, in its sole discretion, may require the Contractor to retain at Contractor's cost an independent testing laboratory.
- B. If the Contractor encounters a Hazardous Waste which may cause foreseeable injury or damage, Contractor shall immediately: (i) secure or otherwise isolate such condition; (ii) stop all Work in connection with such material or substance (except in an emergency situation); and (iii) notify the City (and promptly thereafter confirm such notice in writing).
- C. Subject to Contractor's compliance with this Article 5.6(B), the City shall verify the presence or absence of the Hazardous Waste reported by the Contractor, except as qualified under Article 5.6(A) and Article 5.6(B) in the event such material or substance is found to be present, verify that the levels of the hazardous material are

below OSHA Permissible Exposure Levels and below levels which would classify the material as a state of California or federal hazardous waste. When the material falls below such levels, Work in the affected area shall resume upon direction by the City.

- D. Contractor shall indemnify and hold harmless the City from and against claims, damages, losses and expenses, arising from a Hazardous Waste on the Project Site, if such Hazardous Waste exceeded OSHA Permissible Exposure Levels or levels which would classify the material as a state of California or federal hazardous waste, and was either i) shown on the Contract Documents or information available to proposers; or (ii) brought to the site by Contractor. Nothing in this paragraph shall obligate the Contractor to indemnify the City in the event of the sole or active negligence or willful misconduct of the City, its officers, agents, or employees.

5.7 Sanitary Facilities.

- A. Contractor shall provide sanitary temporary toilet buildings and hand washing facilities for the use of all workers. All toilets and hand washing facilities shall comply with local codes and ordinances. Toilets shall be placed inside sealed secondary containment devices installed on a flat, level surface. Accumulated liquids in the secondary containment devices shall be properly removed and legally disposed without spillage onto the ground. Toilets shall be kept supplied with toilet paper and shall have workable door fasteners. Toilets and hand washing facilities shall be serviced no less than once weekly and shall be present in a quantity of not less than 1 per 20 workers as required by Cal/OSHA regulations. The toilets and hand washing facilities shall be maintained in a sanitary condition at all times. Any other sanitary facilities required by Cal/OSHA shall be the responsibility of the Contractor. Maintenance of such sanitation facilities shall be to the satisfaction of the City.

5.8 Dust Control

- A. Contractor, at its expense, shall maintain all excavations, embankments, haul roads, permanent access roads, plant sites, waste disposal areas, borrow areas, and all other work areas free from dust. Industry accepted methods of dust control suitable for the area involved, such as sprinkling, chemical treatment, light bituminous treatment or similar methods, will be permitted as approved by the City.

The Contractor must comply with the City of Coachella's "Fugitive Dust Control" Ordinance. Dust generated by sawcutting, traffic, Contractor's operations, or wind are all included in the definition of dust. The Contractor will be responsible for watering the work area where dust is generated from traffic, contractor's operations, and wind. Contractor's area of operations includes areas outside of roadbed or trench limits where excavation, fill, or stockpiling of dirt or debris has taken place. The Contractor is responsible for monitoring all the above-described areas in the project area during the life of the project, including holidays, after hours, and weekends. Dust control measures and cleaning shall be to the satisfaction of the City.

The Contractor shall prepare for review and approval by the City, the required PM-10 Best Management Practices Plan. The plan shall be prepared in accordance with South Coast Air Quality Management District guidelines. The Contractor shall have

a designated person Certified by the SCAQMD to prepare the PM-10 plan and oversee the approved dust control measures. Dust control shall include, but is not limited to the following:

- 1) Maintain dust control at all times by watering, including developing a water supply, and furnishing and placing all water required for work done in the contract.
- 2) Provide means to prevent track out onto public streets.
- 3) Provide street sweeping and clean-up of material tracked onto public streets.

Water

The Contractor shall make arrangements with the Coachella Water Authority to obtain water from designated fire hydrants at or near the project for use in operations and dust control. It shall be the responsibility of the contractor to pay for the water and any deposits required. All connections to water supply system shall be maintained in a safe and leak free manner at all times and at to the satisfaction of the City. The cost to furnish and apply water shall be included in the unit prices for the various items bid and no additional payment will be allowed, therefore.

5.9 Air Pollution Control

- A. Contractor shall comply with all air pollution control rules, regulations, ordinances and statutes. All containers of paint, thinner, curing compound, solvent or liquid asphalt, or other such materials shall be labeled to indicate that the contents fully comply with the applicable material requirements. The Contractor shall not discharge smoke, dust or any other air contaminants into the atmosphere in such quantity as will violate the regulations of any legally constituted authority.
- B. Without limiting the foregoing, Contractor must fully comply with all applicable laws, rules and regulations in furnishing or using equipment and/or providing services, including, but not limited to, emissions limits and permitting requirements imposed by the Air Quality Management District with jurisdiction over the Project and/or California Air Resources Board (CARB). Contractor shall specifically be aware of the application of these limits and requirements to "portable equipment", which definition includes any item of equipment with a fuel-powered engine. Contractor shall indemnify the City against any fines or penalties imposed by the air quality management district, CARB, or any other governmental or regulatory agency for its violations of Applicable Laws as well as those of its subcontractors or others for whom Contractor is responsible under its indemnity obligations provided for in the Contract Documents.

5.10 Water Quality Management and Compliance

- A. Storm, surface, ground, nuisance, or other waters may be encountered at various times during construction of the Work. The Contractor hereby acknowledges that it has investigated the risk arising from such waters, has prepared its bid accordingly, and assumes any and all risks and liabilities arising therefrom.

- B. Contractor shall keep itself and all subcontractors, staff, and employees fully informed of and in compliance with all local, state and federal laws, rules and regulations that may impact, or be implicated by the performance of the Work including, without limitation, all applicable provisions regulating discharges of storm water; the Federal Water Pollution Control Act (33 U.S.C. § 13000 et seq.); the California Porter-Cologne Water Quality Control Act (Cal Water Code §§ 13000-14950); and any and all regulations, policies, or permits issued pursuant to any such authority. These include but are not limited to California State Water Resources Control Board Order Number 2009-0009-DWQ (NPDES Permit No. CAS000002), as amended by Order Numbers 2010-0014-DWQ, 2012-0006-DWQ, and any subsequent amendment to or renewal thereof, State Water Resources Control Board Order No. 2013-0001-DWQ (NPDES Order No. CAS000004), and any amendment or renewal thereof, and discharge requirements by the Regional Water Quality Control Board for the Riverside County region.
- C. Contractor shall comply with all conditions of the State Water Resources Control Board (“State Water Board”) National Pollutant Discharge Elimination System General Permit for Waste Discharge Requirements for Discharges of Storm Water Runoff Associated with Construction Activity (“Construction General Permit”) for all construction activity which results in the disturbance of more than one acre of total land area or which is part of a larger common area of development. Contractor shall comply with the lawful requirements of the City, and any other applicable municipality, drainage district, or other local agency with jurisdiction over the location where the Work is to be conducted, regarding discharges of storm water to separate storm drain systems or other watercourses under their jurisdiction, including applicable requirements in municipal storm water management programs.
- D. The City has not prepared a Storm Water Pollution Prevention Plan (“SWPPP”) or other storm water compliance plan for the Project Site. Based on the size and amount of disturbed site area, the Contractor shall be responsible for preparing a Storm Water Pollution Prevention Best Management Practices (BMP’s) Plan, installing and managing construction BMPs as specified per State Water Board and approved by the City. Contractor shall include all costs of compliance with specified requirements in the Contract Price.
- E. The City retains the right to develop its own documentation for the Project site, including but not limited to the Stormwater BMP’s, and in the alternative may require Contractor to adopt and implement portions of the City developed BMP’s. The City expressly reserves the right to procure coverage under the Construction General Permit for the Work site if Contractor fails to draft satisfactory BMP’s or otherwise fails to proceed in a manner that complies with the requirements of the Construction General Permit. The City additionally reserves the right to hire additional contractors to maintain compliance at the Work site. Whether Contractor has adequately maintained compliance with the Construction General Permit shall be the City’s sole determination. Any costs incurred by the City in procuring coverage under the Construction General Permit or drafting and/or implementing the BMP’s for the Work site shall be paid by Contractor.
- F. Failure to comply with the Construction General Permit, laws, regulations, and ordinances listed in this Article is a violation of federal and state law. Notwithstanding any other indemnity contained in these Contract Documents,

Contractor agrees to indemnify and hold harmless the City, its officials, officers, agents, employees and authorized volunteers from and against any and all claims, demands, fees, costs, expenses, or losses or liabilities of any kind or nature which the City, its officials, officers, agents, employees and authorized volunteers may sustain or incur for noncompliance with the Permit, laws, regulations, and ordinances listed above, arising out of or in connection with the Work, except for liability resulting from the sole established negligence, willful misconduct or active negligence of the City, its officials, officers, agents, employees or authorized volunteers.

- G. The City reserves the right to defend any enforcement action or civil action brought against the City for Contractor's failure to comply with any applicable water quality law, regulation, or policy. Contractor hereby agrees to be bound by, and to reimburse the City for the costs associated with, any settlement reached between the City and any relevant enforcement entity.

5.11 Environmental Quality Protection

- A. The Contractor shall comply with all requirements of applicable federal, state, and local environmental rules and regulations. Any infractions of said rules and regulations by the Contractor during the term of the Contract, which result in penalties, will be the responsibility of the Contractor. The City operates under several environmental permits issued by various agencies. If due to an action, inaction, or negligence by the Contractor, the City becomes subject to non-compliance penalties, the cost of such penalties shall be borne by the Contractor.
- B. The Contractor shall exercise care to preserve the natural landscape and vegetation and shall conduct operations so as to prevent unnecessary destruction, scarring, or defacing of the natural surroundings in the vicinity of the Work. Movement of crews and equipment within the rights-of-way and over routes provided for access to the Work shall be performed in a manner to prevent damage to property. When no longer required, construction roads shall be restored to original contours. Upon completion of the Work, and following removal of construction facilities and required cleanup, land used for construction purposes and not required for the completed installation shall be scarified and regraded, as required, so that all surfaces are left in a condition that will facilitate natural revegetation, provide for proper drainage, and prevent erosion. Clean-up, grading, and restoration shall be to the satisfaction of the City.
- C. If, in the performance of the Work, evidence of the possible occurrence of any Federally listed threatened or endangered plant or animal is discovered, the Contractor shall notify the City Representative immediately, giving the location and nature of the findings. Written confirmation of the evidence, location and nature of the findings shall be forwarded to City within two (2) Days. The Contractor shall immediately cease all construction activities in the immediate area of the discovery to the extent necessary to protect the endangered plant or animal. If directed by the City Representative, Contractor will refrain from working in the immediate area, suspend the Work in its entirety, or alter its performance to ensure full compliance with all applicable permits, laws and regulations. Any City directed changes to the Work as a result of a siting will be pursuant to the Contract Documents. Any costs or delays incurred by City or the Contractor due to unreasonable or false notification of an endangered plant or animal will be borne by the Contractor.

D. If, in the performance of the Work, Contractor should unearth cultural resources (for example, human remains, animal bones, stone tools, artifacts and/or midden deposits) through excavation, grading, watering or other means, the Contractor shall notify the construction/archeological monitor and/or the City Representative immediately, giving the location and nature of the findings. Written confirmation of the evidence, location and nature of the findings shall be forwarded to the construction/archeological monitor and/or City within two (2) Days. The Contractor shall immediately cease all construction activities in the immediate area of the discovery to the extent necessary to protect the cultural resource. If directed by the City Representative, Contractor will refrain from working in the immediate area, suspend the Work in its entirety, or re-sequence and/or alter its performance to ensure full compliance with all applicable permits, laws and regulations. Should the presence of cultural resources be confirmed, the Contractor will assist the City Representative and the construction/archeological monitor in the preparation and implementation of a data recovery plan. The Contractor shall provide such cooperation and assistance as may be necessary to preserve the cultural resources for removal or other disposition. Any City directed changes to the Work as a result of the cultural resource will be pursuant to the Contract Documents. Should Contractor, without permission, injure, destroy, excavate, appropriate, or remove any cultural resource on or adjacent to the Site, it will be subject to disciplinary action, arrest and penalty under applicable law. The Contractor shall be principally responsible for all costs of mitigation and/or restoration of cultural resources related to the unauthorized actions identified above. Contractor shall be required to pay for unauthorized damage and mitigation costs to cultural resources (historical and archeological resources) as a result of unauthorized activities that damage cultural resources and shall indemnify City pursuant to the Contract Documents.

5.12 Excessive Noise

- A. Contractor shall use only such equipment on the Work and in such state of repair so that the emission of sound therefrom is within the noise tolerance level of that equipment as established by Cal/OSHA. Contractor shall comply with the most restrictive of the following: (1) local sound control and noise level rules, regulations and ordinances and (2) the requirements contained in these Contract Documents, including hours of operation requirements.
- B. No internal combustion engine shall be operated on the Project without a muffler of the type recommended by the manufacturer. Should any muffler or other control device sustain damage or be determined to be ineffective or defective, the Contractor shall promptly remove the equipment and shall not return said equipment to the job until the device is repaired or replaced. Said noise and vibration level requirements shall apply to all equipment on the job or related to the job, including but not limited to, trucks, transit mixers or transit equipment that may or may not be owned by the Contractor.

5.13 Diversion of Recyclable Waste Material

- A. In compliance with the applicable City's waste reduction and recycling efforts, Contractor shall divert all Recyclable Waste Materials to appropriate recycling centers as required for compliance with the local jurisdiction's waste diversion ordinances. Unless otherwise approved or stated by the City, the Contractor will be

required to submit weight tickets and written proof of diversion with its monthly progress payment requests. Contractor shall complete and execute any certification forms required by the City or other applicable agencies to document Contractor's compliance with these diversion requirements. All costs incurred for these waste diversion efforts shall be the responsibility of the Contractor.

5.14 Contractor's Supervision.

- A. Contractor shall continuously keep at the Project site, a competent and experienced full-time Project superintendent acceptable to the City. Superintendent must be able to proficiently speak, read and write in English and shall have the authority to make decisions on behalf of the Contractor. Contractor shall continuously provide efficient supervision of the Project. Project Supervision shall be to the satisfaction of the City.

5.15 Workers.

- A. Contractor shall at all times enforce strict discipline and good order among its employees. Contractor shall not employ on the Project any unfit person or any one not skilled in the Work assigned to him or her.
- B. Any person in the employ of the Contractor whom the City may deem incompetent or unfit, or behave unruly, or disrespectfully, shall be dismissed from the Work and shall not be employed on this Project.

5.16 Independent Contractors.

- A. Contractor shall be an independent contractor for the City and not an employee. Contractor understands and agrees that it and all of its employees shall not be considered officers, employees, or agents of the City and are not entitled to benefits of any kind normally provided employees of the City, including but not limited to, state unemployment compensation or workers' compensation. Contractor assumes full responsibility for the acts and omissions of its employees or agents related to the Work.

5.17 Verification of Employment Eligibility.

- A. By executing the Contract, Contractor verifies that it fully complies with all requirements and restrictions of state and federal law respecting the employment of undocumented aliens, including, but not limited to, the Immigration Reform and Control Act of 1986, as may be amended from time to time, and shall require all subcontractors, sub-subcontractors and consultants to comply with the same. Each person executing this Contract on behalf of Contractor verifies that he or she is a duly authorized officer of Contractor and that any of the following shall be grounds for the City to terminate the Contract for cause: (1) failure of the Contractor or its Subcontractors, sub-subcontractors or consultants to meet any of the requirements provided for in this Article; (2) any misrepresentation or material omission concerning compliance with such requirements; or (3) failure to immediately remove from the Work any person found not to be in compliance with such requirements.

5.18 Labor.

A. Hours of Work

1. As provided in Article 3 (commencing at section 1810), Chapter 1, Part 7, Division 2 of the Labor Code, Contractor stipulates that eight (8) hours of labor shall constitute a legal day's work. The time of service of any worker employed at any time by the Contractor or by any subcontractor on any subcontract under this Contract upon the Work or upon any part of the Work contemplated by this Contract is limited and restricted to eight (8) hours during any one calendar day and 40 hours during any one calendar week, except as hereinafter provided. Notwithstanding the provisions herein above set forth, work performed by employees of Contractor in excess of eight (8) hours per day, and 40 hours during any one week, shall be permitted upon this public work upon compensation for all hours worked in excess of eight (8) hours per day at not less than one and one-half times the basic rate of pay.
2. The Contractor and every Subcontractor shall keep an accurate record showing the name of and actual hours worked each calendar day and each calendar week by each worker employed in connection with the Work or any part of the Work contemplated by this Contract. The record shall be kept open at all reasonable hours to the inspection of the City and to the Division of Labor Law Enforcement, Department of Industrial Relations of the State of California.
3. The Contractor shall pay to the City a penalty of twenty-five dollars (\$25.00) for each worker employed in the execution of this Contract by the Contractor or by any subcontractor for each calendar day during which such worker is required or permitted to work more than eight (8) hours in any calendar day and 40 hours in any one calendar week in violation of the provisions of Article 3 (commencing at section 1810), Chapter 1, Part 7, Division 2 of the Labor Code.
4. Any work necessary to be performed after regular working hours, or on Saturdays, Sundays, or other holidays, shall be performed without additional expense to the City.
5. If Contractor gives notice of an inspection pursuant to the Contract Documents, the City will provide inspection during normal working hours from 7:00 a.m. to 5:00 p.m. Monday through Friday. Requested inspections before or after this time will be charged to the Contractor as reimbursable inspection time. Inspections on Nights or Weekends require Three (3) Business Days' (72 Hours) notice for review and approval. Upon written request and approval the hours may be changed to other limits subject to City/County ordinance.
6. It shall be unlawful for any person to operate, permit, use, or cause to operate any of the following at the Project Site, other than between the hours of 7:00 a.m. to 5:00 p.m., Monday through Friday, with no Work allowed on Weekends, Nights, or City-observed Holidays, unless otherwise approved by the City:
 - a. Powered Vehicles
 - b. Construction Equipment
 - c. Loading and Unloading Vehicles

d. Domestic Power Tools

B. Payroll Records; Labor Compliance

1. Pursuant to Labor Code section 1776, Contractor and all subcontractors shall maintain weekly certified payroll records, showing the names, addresses, Social Security numbers, work classifications, straight time and overtime hours worked each day and week, and the actual per diem wages paid to each journeyman, apprentice, worker, or other employee employed by them in connection with the Work under this Contract. Contractor shall certify under penalty of perjury that records maintained and submitted by Contractor are true and accurate. Contractor shall also require Subcontractor(s) to certify weekly payroll records under penalty of perjury.
2. Pursuant to SB854, all contractors and subcontractors must furnish electronic certified payroll records directly to the Labor Commissioner (aka Division of Labor Standards Enforcement). All contractors and subcontractors must also provide a copy and proof to the City of online submittal within 2 days of online submission.
3. Any stop orders issued by the DIR against Contractor or any Subcontractor that affect Contractor's performance of Work, including any delay, shall be Contractor's sole responsibility. Any delay arising out of or resulting from such stop orders shall be considered Contractor caused delay subject to any applicable liquidated damages and shall not be compensable by the City. Contractor shall defend, indemnify and hold the City, its officials, officers, employees and agents free and harmless from any claim or liability arising out of stop orders issued by the DIR against Contractor or any Subcontractor.
4. The payroll records described herein shall be certified and submitted by the Contractor at a time designated by the City. The Contractor shall also provide the following:
 - a. A certified copy of the employee's payroll records shall be made available for inspection or furnished to such employee or his or her authorized representative on request.
 - b. A certified copy of all payroll records described herein shall be made available for inspection or furnished upon request of the DIR.
5. Any copy of records made available for inspection as copies and furnished upon request to the public or any public agency, the City, the Division of Apprenticeship Standards or the Division of Labor Standards Enforcement shall be marked or obliterated in such a manner as to prevent disclosure of an individual's name, address and social security number. The name and address of the Contractor awarded the Contract or performing the Contract shall not be marked or obliterated.
6. In the event of noncompliance with the requirements of this Article, the Contractor shall have ten (10) Days in which to comply subsequent to receipt of written notice specifying in what respects the Contractor must comply with this Article. Should noncompliance still be evident after such 10-day period, the Contractor shall pay

a penalty of one hundred dollars (\$100.00) to the City for each calendar day, or portion thereof, for each worker, until strict compliance is effectuated. Upon the request of the Division of Apprenticeship Standards or the Division of Labor Standards Enforcement, such penalties shall be withheld from progress payment then due.

7. The responsibility for compliance with this Article shall rest upon the Contractor.

C. Prevailing Rates of Wages

1. The Contractor is aware of the requirements of Labor Code sections 1720 *et seq.* and 1770 *et seq.*, as well as California Code of Regulations, Title 8, Section 16000 *et seq.* (“Prevailing Wage Laws”), which require the payment of prevailing wage rates and the performance of other requirements on certain “public works” and “maintenance” projects. Since this Project involves an applicable “public works” or “maintenance” project, as defined by the Prevailing Wage Laws, and since the total compensation is \$1,000 or more, Contractor agrees to fully comply with such Prevailing Wage Laws. The Contractor shall obtain a copy of the prevailing rates of per diem wages at the commencement of this Contract from the website of the Division of Labor Statistics and Research of the Department of Industrial Relations located at www.dir.ca.gov. Contractor shall make copies of the prevailing rates of per diem wages for each craft, classification, or type of worker needed to perform work on the Project available to interested parties upon request, and shall post copies at the Contractor’s principal place of business and at the Project site. Contractor shall defend, indemnify and hold the City, its officials, officers, employees and authorized volunteers free and harmless from any claims, liabilities, costs, penalties or interest arising out of any failure or alleged failure to comply with the Prevailing Wage Laws.
2. The Contractor shall forfeit as a penalty to the City not more than Two Hundred Dollars (\$200.00), pursuant to Labor Code section 1775, for each calendar day, or portion thereof, for each worker paid less than the prevailing wage rate as determined by the Director of the DIR for such work or craft in which such worker is employed for any public work done under the Contract by it or by any Subcontractor under it. The difference between such prevailing wage rate and the amount paid to each worker for each calendar day or portion thereof, for which each worker was paid less than the prevailing wage rate, shall be paid to each worker by the Contractor.
3. Contractor shall post, at appropriate conspicuous points on the Project Site, a schedule showing all determined general prevailing wage rates and all authorized deductions, if any, from unpaid wages actually earned.

D. Public Works Contractor Registration

1. Pursuant to Labor Code sections 1725.5 and 1771.1, the Contractor and its Subcontractors must be registered with the DIR prior to the execution of a contract to perform public works. By entering into this Contract, Contractor represents that it is aware of the registration requirement and is currently registered with the DIR. Contractor shall maintain a current registration for the duration of the Project. Contractor shall further include the requirements of Labor Code sections 1725.5

and 1771.1 in any subcontract and ensure that all Subcontractors are registered at the time this Contract is entered into and maintain registration for the duration of the Project. Notwithstanding the foregoing, the contractor registration requirements mandated by Labor Code Sections 1725.5 and 1771.1 shall not apply to work performed on a public works project that is exempt pursuant to the small project exemption specified in Labor Code Sections 1725.5 and 1771.1.

E. Employment of Apprentices

1. Contractor and all Subcontractors shall comply with the requirements of Labor Code sections 1777.5 and 1777.6 in the employment of apprentices.
2. Information relative to apprenticeship standards, wage schedules, and other requirements may be obtained from the Director of Industrial Relations, ex officio the Administrator of Apprenticeship, San Francisco, California, or from the Division of Apprenticeship Standards and its branch offices.
3. Knowing violations of Labor Code section 1777.5 will result in forfeiture not to exceed One Hundred Dollars (\$100.00) for each calendar day of non-compliance pursuant to Labor Code section 1777.7.

F. Nondiscrimination/Equal Employment Opportunity

1. Pursuant to Labor Code section 1735 and other applicable provisions of law, the Contractor and its Subcontractors shall not discriminate against any employee or applicant for employment because of race, religious creed, color, national origin, ancestry, physical disability, mental disability, medical condition, marital status, sex, age, sexual orientation, or any other classifications protected by law on this Project. The Contractor will take affirmative action to insure that employees are treated during employment or training without regard to their race, religious creed, color, national origin, ancestry, physical disability, mental disability, medical condition, marital status, sex, age, sexual orientation, or any other classifications protected by law.

G. Debarment of Contractors and Subcontractors

1. Contractors or Subcontractors may not perform work on a public works project with a subcontractor who is ineligible to perform work on a public project pursuant to Labor Code section 1777.1 or 1777.7. Any contract on a public works project entered into between a contractor and a debarred subcontractor is void as a matter of law. A debarred subcontractor may not receive any public money for performing work as a subcontractor on a public works contract. Any public money that is paid, or may have been paid to a debarred subcontractor by a contractor on the project shall be returned to the City. The Contractor shall be responsible for the payment of wages to workers of a debarred subcontractor who has been allowed to work on the Project.

5.19 Subcontracts.

- A. Contractor agrees to bind every Subcontractor to the terms of the Contract Documents as far as such terms are applicable to Subcontractor's portion of the

Work. Contractor shall be as fully responsible to the City for the acts and omissions of its subcontractors and of persons either directly or indirectly employed by its subcontractors, as Contractor is for acts and omissions of persons directly employed by Contractor. Nothing contained in these Contract Documents shall create any contractual relationship between any subcontractor and the City.

- B. The City reserves the right to accept all subcontractors. The City's acceptance of any Subcontractor under this Contract shall not in any way relieve Contractor of its obligations in the Contract Documents.
- C. Prior to substituting any Subcontractor listed in the Proposal Forms, Contractor must comply with the requirements of the Subletting and Subcontracting Fair Practices Act pursuant to California Public Contract Code section 4100 et seq.

5.20 Progress Meetings

- A. **Unless otherwise approved by the City, the Contractor shall schedule and hold regular progress meetings at least weekly and at other times as requested by City or as required by progress of the Work.** The Contractor, City, and all Subcontractors active on the Site shall attend each meeting. Contractor may at its discretion request attendance by representatives of its Suppliers, manufacturers, and other Subcontractors. Unless otherwise stated, the City will preside at the progress meetings and will arrange for keeping and distributing the minutes. The purpose of the meetings is to review the progress of the Work, maintain coordination of efforts, discuss changes in scheduling, and resolve other problems which may develop. During each meeting, the Contractor shall present any issues which may impact its progress with a view to resolve these issues expeditiously. The City may request updated schedules to be presented at the meeting for review and discussion.

5.21 Submittals

- A. Schedule of Submittals. Within five (5) Days after the Notice of Award (unless otherwise approved by City), Contractor will prepare and deliver a Schedule of Submittals to the City that has been fully integrated with the progress schedule and identifies each Submittal required by the Contract Documents as well as the date on which Contractor will deliver each Submittal to the City. Each Submittal must be delivered to the City at least thirty (30) Days prior to the date the material or equipment is scheduled to be incorporated into the Work unless otherwise approved by the City. The Contractor is responsible for any schedule delays resulting from the Submittal process.

- B. Submittal Procedures.-

- 1. Contractor will follow the following procedures for each Submittal:
 - a. Submittals must be transmitted electronically unless otherwise stated or approved by the City.
 - b. Transmittals will be sequentially numbered. Contractor to mark revised Submittals with original number and sequential alphabetic suffix.

- c. Each Submittal will identify the Project, Contractor, Subcontractor and Supplier, pertinent Drawing and Detail number, and Specification Section Number appropriate to Submittal. The selected item shall be clearly marked and indicated as the submitted product, and other similar items that may be listed on the product sheet or catalog shall be crossed out to avoid confusion with the specified item.
 - d. By transmitting a Submittal, Contractor certifies it has reviewed and approved each Submittal, verified products required, field dimensions, adjacent construction work, and that coordination of information is according to requirements of the Work and Contract Documents.
 - e. Identify variations in Contract Documents and product or system limitations that may differ and/or be detrimental to successful performance of completed Work.
 - f. When Submittal is revised for resubmission, Contractor shall promptly address the City's comments and resubmit. Contractor shall identify changes made since previous submission.
 - g. The City's review of Shop Drawings shall not relieve Contractor from responsibility for deviations from the Contract Documents unless Contractor has, in writing, called the City's attention to such deviations at time of submission and the City has taken no exception to the deviation. The City's review of Shop Drawings shall not relieve Contractor from responsibility for errors in Shop Drawings.
 - h. Submittals not required by the Contract Documents or requested by the City will not be acknowledged or processed unless otherwise approved by City.
 - i. Incomplete Submittals will not be reviewed by the City. Delays resulting from incomplete Submittals are not the responsibility of the City.
 - j. Contractor shall not be entitled to any extension of the Contract Times as a result of the Submittal process.
 - k. Contractor shall allow a minimum of 20 working days for review of each Submittals unless otherwise specified in the Contract Documents
 - l. City reserves the right to schedule a site visit with the contractor and material supplier, nursery, quarry, and all other suppliers of material on the project for onsite inspection and "Tagging and Selection" of proposed material slated for use or incorporation into the project.
2. Where a Submittal, Shop Drawing or Sample is required by the Contract Documents or the Schedule of Submittals, any related Work performed prior to the City review and approval of the pertinent submittal will be performed at the sole risk and expense and responsibility of Contractor.
- C. Schedule Milestone for Submittals. Contractor must submit all Submittals required by the Contract Documents in accordance with the Schedule of Submittals. If

Contractor fails to submit the Submittals in accordance with the Schedule of Submittals, Contractor will be solely liable for any delays or impacts caused by the delayed Submittal, whether direct or indirect. Contractor will be liable for the time calculated from the date the Submittal is due until the date a compliant Submittal is made. A compliant Submittal will be one that is complete and satisfies the requirements of the Contract Documents.

Required Submittals, may include but are not limited to:

- A. Site Protection Plans
- B. Traffic Control Plan
- C. Project Schedule
- D. Stormwater BMP's
- E. Dust Control BMP's
- F. Material Certifications
- G. Asphalt Mix Designs
- H. Other project specific items as requested

5.22 Shop Drawings and Sample Submittal Procedures.

A. Before submitting each Shop Drawing or Sample, Contractor shall have:

1. Reviewed and coordinated each Shop Drawing or Sample with other Shop Drawings and Samples and with the requirements of the Work and the Contract Documents;
2. Determined and verified all field measurements, quantities, dimensions, specified performance and design criteria, installation requirements, materials, catalog numbers, and similar information with respect thereto;
3. Determined and verified the suitability of all materials offered with respect to the indicated application, fabrication, shipping, handling, storage, assembly, and installation pertaining to the performance of the Work; and
4. Determined and verified all information relative to Contractor's responsibilities for means, methods, techniques, sequences, and procedures of construction, and safety precautions and incidental programs.

B. With each Submittal, Contractor shall give the City specific written notice of any variations that the Shop Drawing or Sample may have from the requirements of the Contract Documents. This notice shall be both a written communication separate from the Shop Drawings or Sample Submittal and, in addition, a specific notation made on each Shop Drawing or Sample submitted to the City for review and approval of each such variation.

C. Shop Drawings.

1. Data shown on the Shop Drawings will be complete with respect to quantities, dimensions, specified performance and design criteria, materials, and similar data to show the City the services, materials, and equipment Contractor proposes to

provide and to enable the City to review the information for assessing conformance with information given and design concept expressed in Contract Documents.

2. When required by individual Specification sections, Shop Drawings shall be signed and sealed by a professional engineer responsible for designing components shown on Shop Drawings. Shop Drawings must include signed and sealed calculations to support design in a form suitable for submission to and approval by authorities having jurisdiction.
 3. Shop Drawings for steel structures shall consist of shop details, erection and other working Drawings showing details, dimensions, sizes of members and other information necessary for the complete fabrication and erection of the metal work.
 4. Shop Drawings of concrete structures shall consist of such detailed drawings as may reasonably be required for the successful prosecution of the Work and which are not included in the Drawings furnished by the Engineer. These may include drawings for false work, bracing, centering and form work, masonry layout diagrams, and diagrams for bent reinforcement.
 5. Contractor shall make revisions and provide additional information when required by authorities having jurisdiction.
- D. Samples. Clearly identify each Sample as to material, Supplier, pertinent data such as catalog numbers, the use for which intended and other data as required to enable the City to review the submittal for assessing conformance with information given and design concept expressed in Contract Documents. Samples should be of appropriate size and detail to assess functional, aesthetic, color, texture, patterns and finish selection.
- E. City's Review.
1. The City will review Shop Drawings and Samples in accordance with the Schedule of Submittals. The City's review and acceptance will be only to determine if the items covered by the Submittals will, after installation or incorporation in the Work, conform to the information given in the Contract Documents and be compatible with the design concept of the completed Project as a functioning whole as indicated by the Contract Documents.
 2. The City review and approval will not extend to means, methods, techniques, sequences, or procedures of construction (except where a particular means, method, technique, sequence, or procedure of construction is specifically and expressly called for by the Contract Documents) or to safety precautions or programs incident thereto. The review and approval of a separate item as such will not indicate approval of the assembly in which the item functions.
 3. The City's review and acceptance shall not relieve Contractor from responsibility for any variation from the requirements of the Contract Documents unless the City has given written approval of each such variation by specific written notation thereof incorporated in or accompanying the Shop Drawing or Sample.
- F. Resubmittal Procedures. Contractor shall make corrections required by the City and shall return corrected Shop Drawings and submit, as required, new Samples for

review and approval. Contractor shall direct specific attention in writing to revisions other than the corrections called for by the City on previous Submittals.

5.23 Separate Contracts and Cooperation

- A. Separate Contracts. The City reserves the right to let other contracts in connection with this Work or on the Project site. Contractor shall permit other contractors' reasonable access and storage of their materials and execution of their work and shall properly connect and coordinate its Work with theirs. To ensure proper execution of its subsequent Work, Contractor shall immediately inspect work already in place and shall at once report to the Engineer any problems with the Work in place or discrepancies with the Contract Documents.
- B. Cooperation. Contractor shall ascertain to its own satisfaction the scope of the Project and nature of any other contracts that have been or may be awarded by the City in prosecution of the Project to the end that Contractor may perform this Contract in the light of such other contracts, if any. Nothing herein contained shall be interpreted as granting to Contractor exclusive occupancy at site of the Project. Contractor shall not cause any unnecessary hindrance or delay to any other contractor working on the Project. If simultaneous execution of any contract for the Project is likely to cause interference with performance of some other contract or contracts, the Engineer shall decide which Contractor shall cease Work temporarily and which contractor shall continue or whether work can be coordinated so that contractors may proceed simultaneously. The City shall not be responsible for any damages suffered or for extra costs incurred by Contractor resulting directly or indirectly from award, performance, or attempted performance of any other contract or contracts on the Project Site.

5.24 Work Site.

- A. Limitation of Use of Site and Other Areas. Rights-of-way, easements, or rights-of-entry for the Work will be provided by the City. Unless otherwise specified in the Special Provisions, the Contractor shall make arrangements, pay for, and assume all responsibility for acquiring, using, and disposing of additional work areas and facilities temporarily required. The Contractor shall indemnify and hold the City harmless from all claims for damages caused by such actions. Contractor shall confine construction equipment, the storage of materials and equipment, and the operations of workers to the Site and other areas permitted by Applicable Laws, and shall not unreasonably encumber the Site and other areas with construction equipment or other materials or equipment. Contractor shall assume full responsibility for any damage to any such land or area, or to City or occupant thereof, or of any adjacent land or areas resulting from the performance of the Work.
- B. Site Maintenance. During the progress of the Work, Contractor shall keep the Site and other areas free from accumulations of waste materials, rubbish, and other debris. Removal and disposal of such waste materials, rubbish, and other debris shall conform to Applicable Laws. The Contractor shall furnish trash bins for all debris from construction. All debris shall be placed in trash bins daily and such bins legally emptied or replaced when full. Forms and false-work that are to be re-used shall be stacked neatly concurrently with their removal. Forms and false-work that are not to be re-used shall be disposed of concurrently with their removal.

- C. Cleaning. Prior to Completion of the Work, Contractor shall clean the Site and make it ready for utilization by the City. At the completion of the Work Contractor shall remove from the Site all tools, appliances, construction equipment and machinery, and surplus materials and shall restore to original condition all property not designated for alteration by the Contract Documents. Contractor shall apply soil stabilizer to all areas disturbed by his operations. Site cleanliness and stabilization shall be to the satisfaction of the City.

5.25 Utility Usage.

- A. All temporary utilities, including but not limited to electricity, water, gas, and telephone, used on the Work shall be furnished and paid for by Contractor. Contractor shall provide necessary temporary distribution systems, including meters, if necessary, from distribution points to points on the Work where the utility is needed. Upon completion of the Work, Contractor shall remove all temporary distribution systems. Contractor shall provide necessary and adequate utilities and pay all costs for water, electricity, gas, oil, and sewer charges required for completion of the Work, including but not limited to startup and testing required in the Contract Documents. The City will assist in the utility coordination and application process, and all permanent meters installed shall be listed in the City's name. For Work to be performed in existing City facilities, Contractor may use the City's existing utilities upon City approval, provided such use is reasonable under the circumstances. If Contractor uses the City utilities, it will not need to compensate the City for reasonable consumption of utilities, but Contractor will be responsible for any excessive, unreasonable or wasteful utility usage. Amounts due the City under this section may be deducted from progress payments.

5.26 Protection of Work and Property.

- A. The Contractor is responsible for his own video and photo documentation of existing conditions, and shall be responsible for any damage or further damage caused by his operations. Contractor shall be responsible for the proper care and protection of all materials delivered and Work performed until completion and final acceptance by the City. All Work shall be solely at the Contractor's risk.
- B. Contractor shall adequately protect adjacent property from settlement or loss of lateral support as necessary. Contractor shall comply with all applicable safety laws and building codes to prevent accidents or injury to persons on, about, or adjacent to the Project site where Work is being performed. Contractor shall erect and properly maintain at all times, as required by field conditions and progress of work, all necessary safeguards, proper chain link or other approved fencing, signs, barriers, lights, and watchmen for protection of workers and the public, and shall post danger signs warning against hazards created in the course of construction.
- C. Contractor shall provide such heat, covering, and enclosures as are necessary to protect all Work, materials, equipment, appliances, and tools against damage by weather conditions.
- D. Contractor shall take adequate precautions to protect existing sidewalks, curbs, pavements, utilities, and other adjoining property and structures, and to avoid

damage thereto, and Contractor shall repair any damage thereto caused by the Work operations. Contractor shall:

1. Enclose the working area with an appropriate and approved barricade, and arrange work to cause minimum amount of inconvenience and danger to the public.
 2. Provide substantial or appropriate approved barricades around any shrubs or trees indicated to be preserved.
 3. Deliver materials to the Site over a route designated or approved by the City.
 4. Provide any and all dust control required and follow the applicable air quality regulations as appropriate. If the Contractor does not comply immediately with a notice from the City or a public agency responsible for air quality, the City shall have the authority to provide dust control and deduct the cost from payments to the Contractor.
 5. Confine Contractor's apparatus, the storage of materials, and the operations of its workers to limits required by law, ordinances, permits, or directions of the City. Contractor shall not unreasonably encumber the Site with its materials.
 6. Take care to prevent disturbing or covering any survey markers, monuments, or other devices marking property boundaries or corners. If such markers are disturbed by accident, they shall be replaced by the City's Land Surveyor and the contractor shall be responsible for such costs, which may be deducted for payments due to the contractor.
 7. Ensure that existing facilities, fences and other structures are all adequately protected and that, upon completion of all Work, all facilities that may have been damaged are restored to the satisfaction of the City.
 8. Preserve and protect from injury all buildings, pole lines and all directional, warning and mileage signs that have been placed within the right-of-way.
 9. At the completion of work each day, leave the Work and the Site in a clean, safe condition. Site cleanliness and safety shall be to the satisfaction of the City.
 10. Comply with any stage construction and/or traffic handling plans. Access to residences and businesses shall be maintained at all times, except with the City's written approval. Any request for approval to reduce or restrict access to residences and business must be submitted to the City at least seven (7) Days in advance, and the City may issue or withhold approval in its sole discretion.
- E. These precautionary measures will apply continuously and not be limited to normal working hours. Full compensation for the work involved in the protection and preservation of life, safety and property as above specified shall be considered as included in the prices paid for the various contract items of Work, and no additional allowance will be made therefor.

- F. Should damage to persons or property occur as a result of the Work, Contractor shall promptly notify the City, in writing. Contractor shall be responsible for proper investigation, documentation, including video or photography, to adequately memorialize and make a record of what transpired. The City shall be entitled to inspect and copy any such documentation, video, or photographs.
- G. Contractor shall maintain all investigation documentation including video and/or photographs for a minimum of four (4) years following completion of the Project.

5.27 Emergencies.

- A. In emergencies affecting the safety or protection of persons or the Work or Property at the Site or adjacent thereto, the Contractor, without special instruction or authorization from the City or the Engineer, is obligated to act to prevent threatened damage, injury or loss. The Contractor shall give the Engineer prompt written notice if the Contractor believes that any significant changes in the Work or variations from the Contract Documents have been caused thereby.

ARTICLE 6 - MATERIALS; INSPECTION

6.1 Access to Work.

- A. The City, Engineer, their consultants and other representatives and personnel, independent testing laboratories, and governmental agencies with jurisdictional interests will have access to the Site and the Work **at all times** for their observation, inspection, and testing. Contractor shall provide them proper and safe conditions for such access and advise them of Contractor's safety procedures and programs.

6.2 Materials.

- A. Except as otherwise specifically stated in the Contract Documents, Contractor shall provide and pay for all materials, labor, tools, equipment, water, lights, power, transportation, superintendence, temporary constructions of every nature, and all other services and facilities whatsoever necessary to execute and complete this Contract within the Contract Time. Unless otherwise specified, all materials, parts, and equipment furnished by the Contractor in the Work shall be new, the best of their respective kinds and grades as noted and/or specified, and workmanship shall be of High Quality.
- B. No materials, supplies, or equipment for Work under this Contract shall be purchased subject to any chattel mortgage or under a conditional sale or other agreement by which an interest therein or in any part thereof is retained by the seller or supplier. Contractor warrants good title to all material, supplies, and equipment installed or incorporated in the Work and agrees upon completion of all work to deliver the Project, to the City free from any claims, liens, or charges.
- C. Materials shall be furnished in ample quantities and at such times as to ensure uninterrupted progress of the Work and shall be stored properly and protected as required by the Contract Documents, Storm Water, SQAMD, and other applicable ordinances. Contractor shall be entirely responsible for damage or loss by weather or other causes to materials or Work. Materials shall be stored on the Project Site

in such manner so as not to interfere with any operations of the City or any independent contractor. Material storage shall be to the satisfaction of the City.

- D. Contractor shall verify all measurements, dimensions, elevations, and quantities before ordering any materials or performing any Work, and the City shall not be liable for Contractor's failure to do so. Except for an adjustment to Unit Price Work for item overruns and overruns in accordance with the Contract Documents, no additional compensation, over and above payment for the actual quantities at the prices set out in the Bid Schedule, will be allowed because of differences between actual measurements, dimension, elevations and quantities and those indicated on the Plans and in the Specifications. Any difference therein shall be submitted to the Engineer for consideration before proceeding with the Work.

6.3 Test and Inspections.

A. Inspection and Testing of Work and Materials

Materials testing for this project will be coordinated and provided by the City. The City inspector will notify the Contractor when materials will be tested and coordinate accordingly. However, testing may be random as determined by the City. **The City's Inspectors or representatives shall have the right to access the site at all times, take photos or video of the project or project personnel, interview and/or converse with all project staff, with or without the permission of the superintendent, foreman, or other personnel. All work performed which has not been inspected by the City due to contractor's failure to request or notify the City of an inspection, or denial of access to the site or item to be inspected may result in rejection of that item of work, non-payment of item, and/or non-payment until the item is properly inspected by the City.**

- B. If the Contract Documents, the Engineer, or any instructions, laws, ordinances, or public authority requires any part of the Work to be tested or approved, Contractor shall provide the Engineer at least two (2) working days' notice of its readiness for observation or inspection. If inspection is by a public authority other than the City, Contractor shall promptly inform the City of the date fixed for such inspection. Required certificates of inspection (or similar) shall be secured by Contractor. Costs for City testing and inspection shall be paid by the City. Costs of tests for Work found not to be in compliance shall be paid by the Contractor.
 - 1. The Contractor shall pay for the cost of any minimum "show up" costs of a materials testing technician that was called for by the Contractor but ultimately the Contractor work was not ready for the inspection. Any such costs shall be deducted from any amounts due to the Contractor.
 - 2. If any Work is completed or covered up without the required testing or approval, the Contractor shall uncover or deconstruct the Work, and the Work shall be redone after completion of the testing at the Contractor's cost in compliance with the Contract Documents.
 - 3. Where inspection and testing are to be conducted by an independent laboratory or agency, materials or samples of materials to be inspected or tested shall be selected by such laboratory or agency, or by the City, and not by the Contractor.

Unless otherwise stated and as provided by the Contract Documents, the City shall employ and pay for the services of an independent testing laboratory to perform all inspections, tests, or approvals required by the Contract Documents. All tests or inspections of materials shall be made in accordance with the commonly recognized standards of national organizations.

4. Re-examination of Work may be ordered by the City. If so ordered, Work must be uncovered or deconstructed by the Contractor. If Work is found to be in accordance with the Contract Documents, the City shall pay the costs of reexamination and reconstruction. Unless such work was performed without knowledge of or inspection by the City, or if such work is found not to be in accordance with the Contract Documents, the Contractor shall pay all costs.

Typical Inspections may include but not be limited to:

1. Demolition, Removal Layouts, and Work
2. Clearing & Grubbing
3. Asphalt Preparation, Placement & Compaction
4. Concrete Removals and Patching
5. Work Zone/Site Protection & Safety
6. Dust Control, Stormwater Prevention and NPDES Control Measures
7. And Others as Determined by the City.

C. Testing of Materials

1. In advance of manufacture of materials to be supplied by Contractor which must be tested or inspected, Contractor shall notify the City so that the City may arrange for testing at the source of supply. Any materials which have not satisfactorily passed such testing and inspection shall not be incorporated into the Work.
2. If the manufacture of materials to be inspected or tested will occur in a plant or location greater than sixty (60) miles from the City, the Contractor shall pay for any excessive or unusual costs associated with such testing or inspection, including but not limited to excessive travel time, standby time and required lodging.
3. Unless otherwise specified in the Special Provisions, all initial testing and a reasonable amount of retesting will be performed under the direction of the Engineer, and at no expense to the Contractor. The Contractor shall notify the Engineer in writing, at least 15 days in advance, of its intention to use materials for which tests are specified, to allow sufficient time to perform the tests. The notice shall name the proposed supplier and source of material. If the notice of intent to use is sent before the materials are available for testing or inspection, or is sent so far in advance that the materials on hand at the time will not last but will be replaced by a new lot prior to use on the Work, it will be the Contractor's responsibility to re-notify the Engineer when samples which are representative may be obtained.
4. A Certificate of Compliance shall be furnished to the Engineer prior to the use of any material or assembled material for which these Specifications so require or if so required by the Engineer. The Engineer may waive the materials testing requirements and accept a Certificate of Compliance. Material test data may be required by the Engineer to be included with the submittal. Materials used on the

basis of a Certificate of Compliance may be sampled and tested at any time. The submission of a Certificate of Compliance shall not relieve the Contractor of responsibility for incorporating material into the Work which conforms to the requirements of the Contract Documents. Any material not conforming to the requirements will be subject to rejection by the Engineer whether in place or not.

5. Copies of mill certificates of composition and quality of all component materials (reinforcing steel, structural steel, lumber, etc.) incorporated in the construction of the Work shall be provided to the City at the time of delivery. City shall retain the right to reject any raw material not provided with a mill certificate at the time of delivery.
6. If, after incorporating such materials into the Work, it is found that sources of supply that have been approved do not furnish a uniform product, or if the product from any source proves unacceptable at any time, the Contractor shall furnish approved material from other approved sources. If any product proves unacceptable after improper storage, handling or for any other reason it shall be rejected, not incorporated into the Work, and shall be removed from the Project Site all at the Contractor's expense.

6.4 Requests for Substitutions.

- A. For the purposes of this provision, the term "substitution" shall mean the substitution of any material, method or service substantially equal to or better in every respect to that indicated in the Standard Specifications or otherwise referenced herein.
- B. Pursuant to Public Contract Code section 3400(b), the City may make a finding that is described in the Notice Inviting Bids that designates certain products, things, or services by specific brand or trade name.
- C. Unless specifically designated in the Special Conditions, whenever any material, process, or article is indicated or specified by grade, patent, or proprietary name or by name of manufacturer, such specifications shall be deemed to be used for the purpose of facilitating the description of the material, process, or article desired and shall be deemed to be followed by the words "or equal." Contractor may, unless otherwise stated, offer for substitution any material, process, or article which may be substantially equal to or better in every respect to that so indicated or specified in the Contract Documents. However, the City has adopted uniform standards for certain materials, processes, and articles.
- D. The Contractor shall submit substitution requests, together with substantiating data, for substitution of any "or equal" material, process, or article no later than thirty-five (35) calendar days after award of Contract unless otherwise approved or directed by the City. "First Order" Items of Work substitution requests shall be made A.S.A.P. after Award and prior to the Preconstruction Meeting. Provisions regarding submission of substitution requests shall not in any way authorize an extension of time for the performance of this Contract. If a substitution request is rejected by the City, the Contractor shall provide the material, method or service specified herein. The City shall not be responsible for any costs incurred by the Contractor associated with substitution requests. The burden of proof as to the equality of any material, process, or article shall rest with the Contractor. The Engineer has the complete

and sole discretion to determine if a material, process, or article is substantially equal to or better than that specified and to approve or reject all substitution requests.

- E. Substantiating data as described above shall include, at a minimum, the following information:
 - 1. A signed affidavit from the Contractor stating that the material, process, or article proposed as a substitution is substantially equal to or better than that specified in every way except as may be listed on the affidavit.
 - 2. Illustrations, specifications, catalog cut sheets, and any other relevant data required to prove that the material, process, or article is substantially equal to or better than that specified.
 - 3. A statement of the cost implications of the substitution being requested, indicating whether and why the proposed substitution will reduce or increase the amount of the contract.
 - 4. Information detailing the durability and lifecycle costs of the proposed substitution.
- F. Failure to submit all the required substantiating data detailed above in a timely manner so that the substitution request can be adequately reviewed may result in rejection of the substitution request. The Engineer is not obligated to review multiple submittals related the same substitution request resulting from the Contractor's failure to initially submit a complete package.
- G. Time limitations within this Article shall be strictly complied with and in no case will an extension of time for completion of the contract be granted because of Contractor's failure to provide substitution requests at the time and in the manner described herein.
- H. The Contractor shall bear the costs of all the City work associated with the review of substitution requests unless otherwise approved or waived by the City.
- I. If substitution requests approved by the Engineer require that Contractor furnish materials, methods or services more expensive than that specified, the increased costs shall be borne by Contractor.

ARTICLE 7 - SUBSURFACE AND PHYSICAL CONDITIONS; UTILITIES

7.1 Ownership of Site Materials Found.

- A. The title to water, soil, rock, gravel, sand, minerals, timber and any other materials developed or obtained in the excavation or other operations of Contractor or any of its Subcontractors in the performance of the Contract, and the right to use said items in carrying out the Contract, or to dispose of same, is hereby expressly reserved by the City. Neither Contractor nor any of its Subcontractors nor any of their representatives or employees shall have any right, title, or interest in said materials, nor shall they assert or make any claim thereto. Contractor will, as determined by the City's Representative, be permitted to use in the Work without charge, any such materials which meet the requirements of the Contract Documents, provided the City

shall have the right to use or consume these materials without payment to a third party.

7.2 Existence of Utilities at the Work Site.

A. Existing Utilities

1. The location of known existing utilities and pipelines are shown on the Plans in their approximate locations. However, nothing herein shall be deemed to require the City to indicate the presence of existing service laterals or appurtenances whenever the presence of such utilities on the site of the project can be inferred from the presence of other visible facilities, such as buildings, cleanouts, meter and junction boxes, on or adjacent to the Project.
2. The City will assume the responsibility for the timely removal, relocation, or protection of existing main or trunk line utility facilities located on the Project site if such utilities are not identified by the City in the Contract Documents or which cannot reasonably be inferred from the presence of other visible facilities.

B. Utility Location

1. It shall be the Contractor's responsibility to determine the exact location and depth of all utilities, including service connections, which have been marked by the respective utility owners and which the Contractor believes may affect or be affected by the Contractor's operations. The Contractor shall not be entitled to additional compensation nor time extensions for work necessary to avoid interferences nor for repair to damaged utilities if the Contractor does not expose all such existing utilities as required by this Article.
2. The locating of utilities shall be in conformance with Government Code Section 4216 et seq. except for the City's utilities located on the City's property and not on public right-of-way.
3. A "High Priority Subsurface Installation" is defined in Government Code Section 4216 (j) as "high-pressure natural gas pipelines with normal operating pressures greater than 415kPA gauge (60psig) or greater than six inches nominal pipe diameter, petroleum pipelines, pressurized sewage pipelines, high-voltage electric supply lines, conductors, or cables that have a potential to ground of greater than or equal to 60kv, or hazardous materials pipelines that are potentially hazardous to workers or the public if damaged."
4. A "Subsurface Installation" is defined in Government Code Section 4216 (s) as "any underground pipeline, conduit, duct, wire, or other structure, except nonpressurized sewer lines, nonpressurized storm drains, or other nonpressurized drain lines."
5. Pursuant to Government Code Section 4216.2 the Contractor shall contact the appropriate regional notification center at least two (2) working days but not more than 14 Days before performing any excavation. The date of the notification shall not count as part of the two-working-day notice. Before notifying the appropriate regional notification center, the Contractor shall delineate the area to be

excavated. The Contractor shall request that the utility owners conduct a utility survey and mark or otherwise indicate the location of their service. The Contractor shall furnish to the Engineer written documentation of its contact(s) with the regional notification center prior to commencing excavation at such locations.

6. After the utility survey is completed, the Contractor shall commence "potholing" or hand digging to determine the actual location of the pipe, duct, or conduit and in accordance with Government Code Section 4216.4 if the excavation within the "tolerance zone" of a subsurface installation. The Engineer shall be given notice prior to commencing potholing operations. The Contractor shall uncover all piping and conduits, to a point one (1) foot below the pipe, where crossings, interferences, or connections are shown on the Drawings and report results to the City prior to trenching or excavating for any pipe or structures, or to determine actual elevations. New pipelines shall be laid to such grade as to clear all existing facilities which are to remain in service for any period subsequent to the construction of the run of pipe involved.
7. The Contractor's attention is directed to the requirements of Government Code Section 4216.2 (c) which provides: "When the excavation is proposed within 10 feet of a high priority subsurface installation, the operator of the high priority subsurface installation shall notify the excavator of the existence of the high priority subsurface installation to set up an onsite meeting prior to the legal excavation start date and time or at a mutually agreed upon time to determine actions or activities required to verify the location and prevent damage to the high priority subsurface installation. As part of the meeting, the excavator shall discuss with the operator the method and tools that will be used during the excavation and the information the operator will provide to assist in verifying the location of the subsurface installation. The excavator shall not begin excavating until after the completion of the onsite meeting and approval of the Utility Owner or City. The Contractor shall notify the Engineer and Utility Owner at least 72 hours in advance of this meeting.

C. Utility Relocation and Repair

1. If interferences occur at locations other than those indicated in the Contract Documents with reasonable accuracy, the Contractor shall notify the Engineer in writing. The Engineer will supply a method for correcting said interferences in accordance with the responsibilities of this section and Government Code Section 4215. To the extent any delay is caused thereby, Contractor shall submit a notice of delay within five (5) Days of discovery of the circumstances giving rise to the delay in accordance with Article 9.1 Change Orders and Time Extensions.
2. Care shall be exercised by the Contractor to prevent damage to adjacent existing facilities and public or private works. Where equipment will pass over these obstructions, suitable planking shall be placed. If high priority subsurface installations are damaged and the Utility Owner/Operator cannot be contacted, the Contractor shall call 911 emergency services.
3. The City will compensate the Contractor for the costs of locating and repairing damage not due to the failure of the Contractor to exercise reasonable care, and for removing or relocating such main or trunk line utility facilities not indicated in

the Contract Documents with reasonable accuracy, and for the cost of equipment on the Project necessarily idled during such work. The payment for such costs will be made as provided in Article 9.1 Change Orders and Time Extensions. The Contractor shall not be assessed liquidated damages for delay in completion of the Project, when such delay is caused by the failure of the City or utility company to provide for removal or relocation of such utility facilities. Requests for extensions of time arising out of utility relocation or repair delays shall be filed in accordance with Article 9.1 Change Orders and Time Extensions and Article 9.3 Time for Completion and Liquidated Damages.

4. The public utility, where it is the owner of the affected utility, shall have the sole discretion to perform repairs or relocation work or permit the Contractor to do such repairs or relocation work at a reasonable price. The right is reserved to the City and the owners of utilities or their authorized agents to enter upon the Work area for the purpose of making such changes as are necessary for the rearrangement of their facilities or for making necessary connections or repairs to their properties. The Contractor shall cooperate with forces engaged in such work and shall conduct its operations in such a manner as to avoid any unnecessary delay or hindrance to the work being performed by such forces and shall allow the respective utilities time to relocate their facility.
5. When the Contract Documents indicate that a utility is to be relocated, altered or constructed by others, the City will conduct all negotiations with the utility company and the work will be done at no cost to the Contractor, unless otherwise stipulated in the Contract Documents.
6. Temporary or permanent relocation or alteration of utilities desired by the Contractor for its own convenience shall be the Contractor's responsibility and it shall make arrangements and bear all costs for such work. Such operations shall be approved by the Utility Owner and/or City prior to such relocation or alteration work commences.

D. Construction at Existing Utilities

1. Where the Work to be performed crosses or otherwise interferes with water, sewer, gas, or oil pipelines; buried cable; or other public or private utilities, the Contractor shall perform construction in such a manner so that no damage will result to either public or private utilities. It shall be the responsibility of the Contractor to determine the actual locations of, and make accommodations to maintain, all utilities.
2. Before any utility is taken out of service, permission shall be obtained in advance by the Contractor from the City, Utility Owner, and/or Property Owner. The owner, tenant, any impacted resident, business owner, and the City Representative will be advised in advance of the nature and duration of the utility outage as well as the Contractor's plan for providing temporary utilities as required to sustain the owner, tenant, or business, as approved or directed by the City.
3. The contractor shall work with due diligence to minimize the disruption and outage time of such utilities or services. The contractor may at the direction of the City be responsible for the costs of providing temporary utilities, services, or approved temporary housing or shelter due to any long term disruption of utilities that may

result from the disruption of power, or other vital utilities and services disrupted by the contractor's operations. The Contractor shall be liable for all damage which may result from its failure to maintain utilities during the progress of the Work, and the Contractor shall indemnify City as required by the Contract Documents from all claims arising out of or connected with damage to utilities encountered during construction; damages resulting from disruption of service; and injury to persons or damage to property resulting from the negligent, accidental, or intentional breaching of utilities.

4. Unless otherwise called for by the Contract Documents, the cost of all material, equipment, and labor required to complete this work, shall be included in Contractor's Proposal and distributed in the schedule of pay Items. No additional compensation shall be made to the Contractor for this work.

ARTICLE 8 - PROSECUTION OF THE WORK

8.1 Contractor's Means and Methods.

- A. Contractor is solely responsible for the means and methods utilized to perform the Work. In no case shall the Contractor's means and methods deviate from commonly used industry standards.

8.2 Construction Schedule.

- A. General Requirements. Unless otherwise approved by the City, the contractor shall prepare a Project Schedule in the Critical Path Method ("CPM") format and in an electronic scheduling program acceptable to the City and as specified in the Contract Documents. Contractor shall deliver the schedule and all updates to the City in both paper and electronic form. The electronic versions shall be in the format and include all data used to prepare the schedule. Copies are not acceptable. The preliminary schedule shall be prepared immediately upon award of contract and presented to the City for review and approval prior to the Preconstruction Meeting, or unless otherwise approved by the City.
- B. Schedule. The receipt or approval of any schedules by the City shall not in any way relieve the Contractor of its obligations under the Contract Documents. The Contractor is fully responsible to determine and provide for any and all staffing and resources at levels which allow for good quality and timely completion of the Project. Contractor's failure to incorporate all elements of work required for the performance of the Contract or any inaccuracy in the schedule shall not excuse the Contractor from performing all Work required for a completed Project within the specified Contract Time. If the required schedule is not received by the time the first payment under the Contract is due, Contractor shall not be paid until the schedule is received, reviewed and accepted by the City, unless otherwise approved or waived by the City.
- C. Schedule Contents. The schedule shall allow enough time for inclement weather. The schedule shall indicate the beginning and completion dates of all phases of construction; critical path for all critical, sequential time related activities; and "float time" for all "slack" or "gaps" in the non-critical activities. The schedule shall include appropriate time allowances and constraints for submittals, items of interface with Work performed by others, and specified construction, start-up and performance

tests. Schedules indicating early or late completion will not be accepted by the City and shall not modify or have any effect on the Contract Time. For purposes of determining Liquidated Damages, the Contract Time shall control and may only be altered by a duly authorized Change Order.

- D. Schedule Updates. Contractor shall continuously update its construction schedule. Unless otherwise approved by the City, the Contractor shall submit an updated and accurate construction schedule to the City: (1) prior to Preconstruction Meeting (and the start of construction, if there are any changes to the initial schedule); (2) with each progress payment request; and (3) prior to each progress or construction coordination meeting as directed; and (4) whenever requested to do so by the City. The City may withhold progress payments or other amounts due under the Contract Documents if Contractor fails to submit an updated and accurate construction schedule. Upon the City's request, Contractor shall submit any schedules or updates to the City in the native electronic format of the software used to create the schedule. Contractor shall also submit schedules showing a two-week detailed look-ahead at weekly meetings conducted with the City. The two-week look-ahead schedule shall clearly identify all staffing and other resources which in the Contractor's judgment are needed to complete the Work within the Contract Time, and it shall clearly state the number of staff to be used on each daily segment of the Work.
- E. Acceptance. Acceptance of the schedules by the City will not impose on responsibility for accuracy, for sequencing, scheduling, or progress of the Work, or compliance with the Contract Documents. Acceptance will not interfere with or relieve Contractor from Contractor's full responsibility therefor.
- F. Recovery Schedule.
1. Should any of the following conditions exist, City may require Contractor to prepare, at no extra cost to City, a plan of action and a recovery schedule for completing the Work and achieving all contractual milestones within the allotted Contract Time:
 - a. The Contractor's monthly progress report indicates delays that are, in the opinion of City, of sufficient magnitude that City questions the Contractor's ability to complete the Work;
 - b. The schedule shows the Contractor to be thirty (30) or more days behind the critical path at any time during construction;
 - c. The Contractor desires to make changes in the logic or the planned duration of future activities of the schedule which, in the opinion of City, are major in nature.
 2. The recovery schedule shall include proposed revisions to the Construction Schedule, demonstrating how Contractor intends to achieve all contractual milestones including Contract completion within the allotted Contract Time. The submittal shall include a narrative describing the actions planned by the Contractor to recover the schedule.

3. Contractor shall submit the Recovery Schedule within seven (7) Days of City's request. If Contractor asserts that City is responsible for the delay, failure to submit the recovery schedule within seven (7) Days of City's request, will be considered a concurrent delay event attributable to Contractor, and Contractor shall only be entitled to non-compensable adjustments to Contract Times. If Contractor is responsible for the delay, this provision will not limit or affect Contractor's liability and failure to submit the recovery schedule with seven (7) Days of City's request may result in City withholding progress payments or other amounts due under the Contract Documents.
4. Contractor is responsible for all costs associated with the preparation and execution of the recovery schedule, including any necessary recovery actions, which may include, but are not limited to, assignment of additional labor, and/or equipment, shift or overtime work, expediting of submittals or deliveries, overlapping of activities or sequencing changes to increase activity concurrence. Regardless of whether City directs Contractor to prepare a recovery schedule pursuant to this Section, Contractor shall promptly undertake appropriate action at no additional cost to City to recover the schedule whenever the current construction schedule shows that the Contractor will not achieve a milestone and/or complete the Work within the allotted Contract Time.

8.3 Time for Completion and Liquidated Damages

- A. Time for Completion. The time for completion set forth in Article 2 of the Contract for Construction shall commence: (1) on the date stated in the Notice to Proceed, or (2) if the Notice to Proceed does not specify a commencement date, then on the date of the Notice to Proceed and shall be completed by Contractor in the time specified in the Contract Documents. The City is under no obligation to consider early completion of the Project; and the Contract completion date shall not be amended by the City's receipt or acceptance of the Contractor's proposed earlier completion date. Any difference in time between the Contractor's early completion and the Contract Time shall be considered a part of the Project float. Contractor shall not be entitled to compensation, and the City will not compensate Contractor, for delays which impact early completion. Contractor shall not, under any circumstances, receive additional compensation from the City (including but not limited to indirect, general, administrative or other forms of overhead costs) for the period between the time of earlier completion proposed by the Contractor and the Contract completion date.
- B. Liquidated Damages. If the Work is not completed within the Contract Time(s), it is understood that the City will suffer damage. In accordance with Government Code section 53069.85 and Public Contract Code section 7102, being impractical and infeasible to determine the amount of actual damage, it is agreed that Contractor shall pay to the City as fixed and liquidated damages, and not as a penalty, the sum stipulated in the Contract for each Working Day of delay until the Work is fully completed (to the satisfaction of the City). Contractor and its surety shall be liable for any liquidated damages. Any money due or to become due the Contractor may be retained to cover liquidated damages.
- C. Inclement Weather. Contractor shall abide by the Engineer's determination of what constitutes inclement weather. Time extensions for inclement weather shall only be

granted when the Work stopped during inclement weather is on the critical path of the Project schedule. No other additional compensation will be paid to the contractor for delays caused by inclement weather other than an extension of time.

- D. Extension of Time. Contractor's entitlement to an extension of the Contract Time is limited to a City-caused extension of the critical path, reduced by the Contractor's concurrent delays, and established by a proper time impact analysis. Contractor shall not be charged liquidated damages because of any delays in completion of the Work due to unforeseeable causes beyond the control and without the fault or negligence of Contractor (or its Subcontractors or Suppliers). The City shall ascertain the facts and extent of delay and grant extension of time for completing the Work when, in its judgment, the facts justify such an extension. Contractor shall not be entitled to an adjustment in the Contract Times for delays within the control of Contractor. Delays attributable to and within the control of a Subcontractor or Supplier shall be deemed to be delays within the control of Contractor.
- E. Force Majeure. In accordance with subparagraphs "C" and "D" above, the Contractor shall not be charged liquidated damages, and the City shall not be responsible, for any delays resulting from a Force Majeure Event. If a delay to the critical path results from a Force Majeure Event, the Contractor will be entitled to a time extension but will not receive an adjustment to the Contract Price or any other compensation. Such a non-compensable adjustment shall be Contractor's sole and exclusive remedy for such delays.
- F. No Damages for Reasonable Delay. The City's liability to Contractor for delays for which the City is responsible shall be limited to only an extension of time unless such delays were unreasonable under the circumstances. In no case shall the City be liable for any costs which are borne by the Contractor in the regular course of business, including, but not limited to, home office overhead and other ongoing costs. Damages caused by unreasonable City delay shall be based on actual costs only, no proportions or formulas shall be used to calculate any delay damages.
- G. Procedure for Time Extensions and Delay Damages. Contractor shall not be entitled to any extension of time unless Contractor properly notices the delay and adjustment to compensation and requests a Change Order in accordance with Article 9.1 Change Orders and Time Extensions. Contractor's failure to timely and fully comply with the Change Order procedures in the Contract Documents shall constitute a waiver of Contractor's right to a time extension or reverse liquidated damages.

8.4 Contractor's Responsibility for Work.

- A. Until the Formal Final Acceptance of the Work by the Engineer as evidenced in writing, it shall be under the charge and care of the Contractor. The Contractor shall take every necessary precaution against injury or damage to any part thereof by the action of the elements or from any cause whether arising from the execution or non-execution of the Work. The Contractor shall rebuild, repair, restore and make good at its own expense all injuries or damages to any portion of the Work before its completion and acceptance. In the event of damage proximately caused by an Act of God, as defined by Section 7105 of the Public Contract Code, the City will pay for repair or restoration to damaged Work in excess of 5% of the total Bid.

8.5 Occupancy.

- A. The City reserves the right to occupy or utilize any portion of the Work at any time before completion, and such occupancy or use shall not constitute acceptance of any part of Work covered by this Contract. This use shall not relieve the Contractor of its responsibilities under the Contract.

8.6 Securities for Money Withheld

- A. Pursuant to section 22300 of the Public Contract Code of the State of California, Contractor may request the City to make retention payments directly to an escrow agent or may substitute securities for any money withheld by the City to ensure performance under the contract. At the request and expense of Contractor, securities equivalent to the amount withheld shall be deposited with the City or with a state or federally chartered bank as the escrow agent who shall return such securities to Contractor upon satisfactory completion of the contract. Deposit of securities with an escrow agent shall be subject to a written agreement substantially in the form provided in section 22300 of the Public Contract Code.

8.7 The City's Right to Suspend/Terminate the Contract

A. Suspension of Work by the City

1. The City may, at its sole option, decide to suspend at any time the performance of all or any portion of the Work by notice in writing to Contractor. Such notice of suspension of Work will designate the amount and type of plant, labor, and equipment to be committed to the Project during the period of suspension. Contractor shall use its best efforts to utilize its plant, labor, and equipment in such a manner as to minimize costs associated with suspension.
2. Upon receipt of any such notice, Contractor shall, unless the notice requires otherwise:
 - a. Immediately discontinue Work on the date and to the extent specified in the notice;
 - b. Place no further orders or subcontracts for material, services, or facilities with respect to suspended Work other than to the extent required in the notice;
 - c. Promptly make every reasonable effort to obtain suspension upon terms satisfactory to the City's Representative of all orders, subcontracts, and rental agreements to the extent they relate to performance of Work suspended; and
 - d. Continue to protect and maintain the Work including those portions on which Work has been suspended.
3. Except as provided by this Article, as full and complete compensation for such suspension, Contractor shall be granted an adjustment in the Contract Price based on a negotiated daily rate that reflects the Contractor's actual costs associated with the demobilized condition of the Site and an extension of the Contract Times equal to the number of days performance of Work is suspended; provided, however, that

no adjustment of Contract Price or extension of Contract Times shall be granted if the suspension results from Contractor's non-compliance with the requirements of the Contract.

B. Termination for Cause by the City:

1. In the sole estimation of the City, if the Contractor refuses or fails to prosecute the Work or any separable part thereof with such diligence as will insure its completion within the time specified by the Contract Documents, or any extension thereof, or fails to complete such Work within such time, failure to complete the work in a proper and professional manner in accordance with the project's plans and specifications, failure to supply schedules and project documentation, unprofessional behavior of the contractor, project managers, work force, or other project personnel, or if the Contractor should be adjudged a bankrupt, or if it should make a general assignment for the benefit of its creditors, or if a receiver should be appointed on account of its insolvency, or the Contractor or any of its subcontractors should violate any of the provisions of this Contract, the City may serve written notice upon the Contractor and its surety of the City's intention to terminate this Contract. This notice of intent to terminate shall contain the reasons for such intention to terminate this Contract, and a statement to the effect that the Contractor's right to perform this Contract shall cease and terminate upon the expiration of ten (10) Calendar Days unless such violations have ceased and arrangements satisfactory to the City have been made for correction of said violations.
2. After expiration of the ten (10) Calendar Day period, the City may terminate the Contract by providing a Notice of Termination to the Contractor. The City may take over and complete the Work by any method it may deem appropriate, including enforcement of the Project performance bond. Contractor and its surety shall be liable to the City for any excess costs or other damages incurred by the City to complete the Work. If the City takes over the Work, the City may, without liability for so doing, take possession of and utilize in completing the Work such materials, appliances, plant, and other property belonging to the Contractor as may be on the Site.
3. Upon termination, Contractor shall not be entitled to receive any further payment from the City, except for Work which was duly performed prior to the effective date of the Notice of Termination. Contractor shall submit an invoice for final payment within thirty (30) Days of the effective date of the Notice of Termination. The City may withhold from final payment up to 150% of any disputed amounts, including any amounts which may be necessary to repair defective Work, complete unfinished Work, or are otherwise occasioned by Contractor's failure to perform its duties under the Contract.

C. Termination for Convenience by the City:

1. The City may terminate performance of the Work called for by the Contract Documents in whole or, from time to time, in part, upon ten (10) Calendar Days written notice if the City determines that a termination is in the City's interest.

2. The Contractor shall terminate all or any part of the Work upon delivery to the Contractor of a Notice of Termination specifying that the termination is for the convenience of the City, the extent of termination, and the effective date of such termination.
3. After receipt of Notice of Termination, and except as directed by the City's Representative, the Contractor shall, regardless of any delay in determining or adjusting any amounts due under this termination for convenience clause, immediately proceed with the following obligations:
 - a. Stop Work as specified in the Notice.
 - b. Complete any Work specified in the Notice of Termination in a least cost/shortest time manner while still maintaining the quality called for under the Contract Documents.
 - c. Leave the property upon which the Contractor was working and upon which the facility/facilities forming the basis of the Contract Document is situated in a safe and sanitary manner such that it does not pose any threat to the public health or safety.
 - d. Terminate all subcontracts to the extent that they relate to the portions of the Work terminated.
 - e. Place no further subcontracts or orders, except as necessary to complete the continued portion of the Contract.
 - f. Submit to the City's Representative, within ten (10) Days from the effective date of the Notice of Termination, all of the usual documentation called for by the Contract Documents to substantiate all costs incurred by the Contractor for labor, materials and equipment through the effective date of the Notice of Termination. Any documentation substantiating costs incurred by the Contractor solely as a result of the City's exercise of its right to terminate this Contract pursuant to this clause, which costs the contractor is authorized under the Contract documents to incur, shall: (1) be submitted to and received by the Engineer no later than 30 Days after the effective date of the Notice of Termination; (2) describe the costs incurred with particularity; and (3) be conspicuously identified as "Termination Costs occasioned by the City's Termination for Convenience." If the City rejects any costs, Contractor shall be deemed to waive the rejected costs unless Contractor files a Claim within thirty (30) Days of the rejection pursuant to Article 9.2.
 - g. Contractor shall be entitled to receive only the amounts payable under this Article, and Contractor specifically waives any claim for any other amounts or damages, including, but not limited to, any claim for consequential damages or lost profits. The provisions in this Article are in addition to and not in limitation of any other rights or remedies available to the City.
4. Termination of the Contract shall not relieve surety of its obligation for any just claims arising out of or relating to the Work performed.

5. Notwithstanding any other provision of this Article, when immediate action is necessary to protect life and safety or to reduce significant exposure or liability, the City may immediately order Contractor to cease Work on the Project until such safety or liability issues are addressed to the satisfaction of the City or the Contract is terminated.
6. If the City terminates Contractor for cause, and if it is later determined that the termination was wrongful, such default termination shall automatically be converted to and treated as a termination for convenience. In such event, Contractor shall be entitled to receive only the amounts payable under this section, and Contractor specifically waives any claim for any other amounts or damages, including, but not limited to, any claim for consequential damages or lost profits.

8.8 Completion and Acceptance of Work

- A. Final Inspection. Upon field verification and written notice from Contractor that the entire Work is complete, the City will promptly schedule and conduct a "Final Inspection" with the City and Contractor. The City will submit a "Punch List" to the Contractor in writing of all particulars in which this inspection reveals that the Work is incomplete or defective. Contractor shall immediately take such measures as are necessary to complete such Work or remedy such deficiencies within the time period defined in the Punch List Letter.
- B. Final Acceptance. The acceptance of the Work on behalf of the City will be made by the Engineer. Such acceptance by the City shall not constitute a waiver of defects. After Contractor has, in the opinion of the Engineer, satisfactorily completed all corrections identified during the Final Inspection "Punch List" and has delivered, in accordance with the Contract Documents, all maintenance and operating instructions, schedules, guarantees, bonds, certificates or other evidence of insurance, certificates of inspection, Record Documents, and other documents required by the Contract Documents, the City shall issue a "Notice of Substantial Completion", and if applicable, schedule a formal Final Acceptance by the City Council and at the next possible session, and cause the City Clerk to file a Notice of Completion, constituting Formal Final Acceptance and Completion of the Project.

8.9 Warranty and Guaranty of Work.

- A. Contractor hereby warrants that materials and Work shall be completed in conformance with the Contract Documents and that the materials and Work provided will fulfill the requirements of this Warranty. Contractor hereby agrees to repair or replace, at the discretion of the City, any or all Work that may prove to be defective in its workmanship, materials furnished, methods of installation or fail to conform to the Contract Document requirements together with any other Work which may be damaged or displaced by such defect(s) within a period of one (1) year (or as otherwise indicated in the Contract Documents or in any guarantee or warranty provided by any manufacturer or supplier of equipment or materials incorporated into the Work, whichever is later) from the date of the Notice of Completion of the Project without any expense whatever to the City, ordinary wear and tear and unusual abuse and neglect excepted. Contractor shall be required to promptly repair or replace defective equipment or materials, at Contractor's option. All costs associated with such corrective actions and testing, including the removal, replacement, and

reinstitution of equipment and materials necessary to gain access, shall be the sole responsibility of the Contractor.

- B. For any Work so corrected, Contractor's obligation hereunder to correct defective Work shall be reinstated for an additional one (1) year period, commencing with the date of acceptance of such corrected Work. The reinstatement of the one (1) year warranty shall apply only to that portion of work that was corrected. Contractor shall perform such tests as the City may require to verify that any corrective actions, including, without limitation, redesign, repairs, and replacements comply with the requirements of the Contract. In the event of Contractor's failure to comply with the above-mentioned conditions within ten (10) Days after being notified in writing of required repairs, to the reasonable satisfaction of the City, the City shall have the right to correct and replace any Defective or Non-conforming Work and any work damaged by such work or the replacement or correction thereof at Contractor's sole expense. Contractor shall be obligated to fully reimburse the City for any expenses incurred hereunder immediately upon demand.
- C. In addition to the warranty set forth in this Article, Contractor shall obtain for the City all warranties that would be given in normal commercial practice and assign to the City any and all manufacturer's or installer's warranties for equipment or materials not manufactured by Contractor and provided as part of the Work, to the extent that such third-party warranties are assignable and extend beyond the warranty period set forth in this Article. Contractor shall furnish the City with all warranty and guarantee documents prior to Final Acceptance of the Project by the City.
- D. When specifically indicated in the Contract Documents or when directed by the Engineer, the City may furnish materials or products to the Contractor for installation. In the event any act or failure to act by Contractor shall cause a warranty applicable to any materials or products purchased by the City for installation by the Contractor to be voided or reduced, Contractor shall indemnify the City from and against any cost, expense, or other liability arising therefrom, and shall be responsible to the City for the cost of any repairs, replacement or other costs that would have been covered by the warranty but for such act or failure to act by Contractor.
- E. The Contractor shall remedy at its expense any damage to City-owned or controlled real or personal property.
- F. The City shall notify the Contractor, in writing, within a reasonable time after the discovery of any failure, defect, or damage. The Contractor shall within ten (10) Days after being notified commence and perform with due diligence all necessary Work. If the Contractor fails to promptly remedy any defect or damage, the City shall have the right to replace, repair or otherwise remedy the defect, or damage at the Contractor's expense.
- G. In the event of any emergency constituting an immediate hazard to health, safety, property, or licensees, when caused by Work of the Contractor not in accordance with the Contract requirements, the City may undertake at Contractor's expense, and without prior notice, all Work necessary to correct such condition.
- H. Acceptance of Defective Work.

1. If, instead of requiring correction or removal and replacement of defective Work, the City prefers to accept it, the City may do so. Contractor shall pay all claims, costs, losses, and damages (including but not limited to all fees and charges of engineers, architects, attorneys, and other professionals and all court or arbitration or other dispute resolution costs) attributable to the City's evaluation of and determination to accept such defective Work and for the diminished value of the Work. If any acceptance of Defective Work occurs prior to release of the Project retention, a Change Order will be issued incorporating the necessary revisions in the Contract Documents with respect to the Work, and the City shall be entitled to an appropriate decrease in the Contract Price, reflecting the diminished value of Work and all costs incurred by the City.

I. The City May Correct Defective Work

1. If Contractor fails within a reasonable time after written notice from the City to correct Defective Work, or to remove and replace rejected Work as required by the City, or if Contractor fails to perform the Work in accordance with the Contract Documents, or if Contractor fails to comply with any other provision of the Contract Documents, the City may, after seven (7) Days written notice to Contractor, correct, or remedy any such deficiency.
 2. In connection with such corrective or remedial action, the City may exclude Contractor from all or part of the Site, take possession of all or part of the Work and suspend Contractor's services related thereto, take possession of Contractor's tools, appliances, construction equipment and machinery at the Site, and incorporate in the Work all materials and equipment stored at the Site or for which the City has paid Contractor but which are stored elsewhere. Contractor shall allow the City, and the agents, employees, other contractors, and consultants of each of them, access to the Site to enable the City to exercise the rights and remedies to correct the Defective Work.
 3. All claims, costs, losses, and damages (including but not limited to all fees and charges of engineers, architects, attorneys, and other professionals and all court or arbitration or other dispute resolution costs) incurred or sustained by the City correcting the Defective Work will be charged against Contractor, and a Change Order will be issued incorporating the necessary revisions in the Contract Documents with respect to the Work; and the City shall be entitled to an appropriate decrease in the Contract Price. Such claims, costs, losses and damages will include but not be limited to all costs of repair, or replacement of work of others destroyed or damaged by correction, removal, or replacement of defective Work.
- J. Nothing in the warranty or in the Contract Documents shall be construed to limit the rights and remedies available to the City at law or in equity, including, but not limited to, Code of Civil Procedure section 337.15.

ARTICLE 9 - CHANGE ORDERS; DISPUTE RESOLUTION

9.1 Change Orders and Time Extensions

All changes to the Contract, including compensation increases and time extensions, shall be through a written Change Order in accordance with this Article. The City, without invalidating the Contract, may order changes in the Work consisting of additions, deletions or other revisions, and Contractor's compensation and the time for completion shall be adjusted accordingly. Whenever any change is made as provided for herein, such change shall be considered and treated as though originally included in the Contract, and shall be subject to all terms, conditions, and provisions of the original Contract. Contractor shall not be entitled to claim or bring suit for damages, whether for loss of profits or otherwise, on account of any decrease or omission of any item or portion of Work to be done. No dispute, disagreement, or failure of the parties to reach agreement on the terms of the Change Order shall relieve the Contractor from the obligation to proceed with performance of the Work, including Additional Work, promptly and expeditiously. Any alterations, extensions of time, Additional Work, or any other changes may be made without securing consent of the Contractor's surety or sureties.

Any pending time extensions, additions, reductions, and deletion of Bid Item Quantities will be adjusted accordingly upon the completion of the project and tabulation of the "Final Contract Quantities" via a "Contract Quantity Adjustment Change Order" thereby adjusting the Final Contract Price and time accordingly, prior to formal Final Acceptance by the City. Adjusted quantity "overages" shall not be paid until after the contract quantities and amounts are officially adjusted via change order. Upon execution of the Quantity Adjustment Change Order, the contractor may bill for such adjusted quantities, less retention as applicable and provided for in these project Specifications.

A. Change in Contract Procedures

1. City Directive. The City may direct changes in the Work by delivering a written directive. To the extent the work directive results in a change to compensation or time, Contractor must timely request a Change Order and comply with all Change Order procedures in accordance with this Article. Notwithstanding issuance of a work directive, Contractor's failure to timely request a Change Order shall constitute a waiver by Contractor of any adjustment to compensation or time extension for Work performed under the directive. The City shall not be liable to Contractor for Work performed or omitted by Contractor in reliance on verbal orders.
2. Contractor's Notice of Change/Delay. If Contractor intends to initiate a Change Order Request, then Contractor shall provide the City with written notice of the underlying facts and circumstances that gave rise to the proposed change within the following times:
 - a. If due to unknown subsurface or latent physical conditions, within three (3) days from the discovery date or prior to the alterations of the conditions, whichever is earlier.
 - b. If due to a Force Majeure Event, as soon as reasonably practicable under the conditions, which shall be no longer than three (3) days from the date the Contractor discovers that the Force Majeure Event gives rise to a change, unless

that the conditions are such that notice within three (3) days is not possible or practicable.

- c. If due to any other matter that may involve an adjustment to the Contract Time or the Contract Price, within seven (7) days from the discovery date.

To be considered valid and complete, the notice of change/delay shall include a general statement of the circumstances giving rise to the notice of change/delay and a reasonable order of magnitude estimate of the additional costs and/or time. If the circumstances give rise to both a cost adjustment and time extension, Contractor shall submit the notice of change and notice of delay concurrently.

3. Request for Change in Compensation and/or Extension of Time. Contractor shall submit a Change Order Request for any adjustment to Contractor's compensation and/or any extension of time. The Change Order Request shall be made prior to incurring any expense and within fourteen (14) Days from either Contractor's notice of change/delay or the City's directive ordering the change, or as otherwise approved by the City. The Change Order Request shall include all of the following information (unless inapplicable to the change):

- a. A detailed description of the circumstances giving rise to the request;
- b. A complete itemized cost proposal, including itemized pricing for first tier Subcontractors;
- c. Supporting documentation for all costs;
- d. A time impact analysis showing the impact of the delay to the critical path to completion;
- e. If any added costs or information cannot be determined at the time of the Change Order Request, the reason the costs or information cannot be determined at the time; and
- f. Certification to the accuracy of the Change Order Request under penalty of perjury.

The time impact analysis shall be in the critical path method format and shall show the sequencing of all critical and non-critical new activities and/or activity revisions affected by the delay, with logic ties to all affected existing activities noted on the schedule.

The City may demand, and Contractor shall provide, any additional information supporting the Change Order Request, including but not limited to native electronic format version of schedules and time impact analyses. Contractor shall provide the requested additional information within five (5) Days of the request.

For any costs or information that cannot be determined at the time Contractor submits the Change Order Request, Contractor shall submit to the City notice of the costs or information and all supporting documentation within five (5) Days of when the costs or other information become subject to determination.

4. City's Final Decision on Change Order; Ordered Changes. If the City denies the Change Order Request or disagrees with the proposal submitted by Contractor, it will notify the Contractor, and the City will provide its opinion of the appropriate price and/or time extension. If no agreement can be reached, the City shall also have the right to order changes in the Work to be performed promptly by the Contractor on a Time and Materials Basis (T&M) or to issue a Unilateral Change Order setting forth the City's determination of the reasonable additions or savings in costs and time attributable to the extra or deleted work. The City's determination shall become final and binding if the Contractor fails to submit a Claim in writing to the City within fourteen (14) Days of the issuance of the unilateral Change Order, disputing the terms of the unilateral Change Order and providing such supporting documentation for its position as the City may reasonably require.
5. Contractor's Waiver of Further Relief. Contractor's failure to provide a complete and timely notice of Change / Delay and/or Change Order request, or to comply with any other requirement of this article, shall constitute a waiver by the Contractor of the right to a contract adjustment on account of such circumstances and a waiver of any right to further recourse or recovery by reason of or related to such change by means of the claims despite resolution process or by any other legal process otherwise provided for under applicable laws.

Contractor recognizes and acknowledges that timely submission of a formal written notice of change/delay and Change Order Request, whether or not the circumstances of the change may be known to the City or available to the City through other means, is not a mere formality but is of crucial importance to the ability of the City to promptly identify, prioritize, evaluate and mitigate the potential effects of changes. Any form of informal notice, whether verbal or written (including, without limitation, statements in requests for information, statements in Submittals, statements at any job meeting or entries on monthly reports, daily logs or job meeting minutes), that does not strictly comply with the formal requirements of this Article, shall accordingly be insufficient.

6. Change Order Format

- a. A Change Order signed by the Contractor indicates the Contractor's agreement therewith, including any adjustment in compensation or extension of time, and the full and final settlement of all costs (direct, indirect and overhead) related to the Work authorized by the Change Order.
- b. The City may designate and provide the forms to be used for notices, requests, and Change Orders. If so designated, Contractor may only use such forms. Contractor shall not reserve a right to assert impact costs, extended job site costs, extended overhead, constructive acceleration and/or actual acceleration beyond what is stated in the Change Order. No Claims shall be allowed for impact, extended overhead costs, constructive acceleration and/or actual acceleration due to a multiplicity of changes and/or clarifications. The Contractor may not change or modify the City's Change Order form in an attempt to reserve additional rights.

B. Determining Adjustments to Compensation.

1. Limitation on Costs. Contractor shall not be entitled to any compensation for Work subject to a Change Order except as expressly set forth in this Article. The mark-up

added in instances of Additional Work shall constitute the entire amount of profit, any mark-ups, any field or home office overhead costs, including personnel, equipment or office space, any materials, or any costs of equipment idle time for such Work.

2. Unit Price Change Orders. When the actual quantity of a Unit Price Work item varies from the Bid Schedule, compensation for the change in quantity will be calculated by multiplying the actual quantity by the unit price. This calculation may result in either an additive or deductive Change Order. Bid items included on the Bid Schedule may be deducted from the Work in their entirety without any negotiated extra costs. Because Unit Price Work includes overhead and profit as determined by Contractor at the time of its Proposal submission, no mark up or deduction for overhead and profit will be allowed. Bid Item Quantities will be adjusted accordingly upon the completion of the project and tabulation of the "Final Contract Quantities" via a "Contract Quantity Adjustment Change Order" thereby adjusting the Final Contract Price and Time accordingly, prior to formal Final Acceptance by the City.
3. Lump Sum Change Orders. Whenever possible, any changes affecting compensation shall be in a lump sum mutually agreed by the Contractor and the City.
4. Time and Materials Change Orders. The City may direct the Contractor to proceed with the Additional Work with payment to be made on the basis of actual cost of the labor and materials required to complete the Additional Work. If the Project is federally funded, a time and materials Change Order shall only be issued after a determination that no other Change Order is suitable and the Change Order shall include a ceiling price that the Contractor exceeds at its own risk.
5. Federally Funded Projects. For any change in price to the Contract, general and administrative expenses shall be negotiated and must conform to the cost principles set forth under at 2 C.F.R. Part 200, subpart E, and profit shall be negotiated as a separate element of the cost. To establish a fair and reasonable profit, consideration must be given to the complexity of the Additional Work to be performed, the risk borne by the Contractor, the Contractor's investment, the amount of subcontracting, the quality of its record of past performance, and industry profit rates in the surrounding geographical area for similar work.
6. Allowed Costs. Estimates for lump sum quotations and accounting for time-and-material work shall be limited to direct expenditures necessitated specifically by the change and shall be segregated as follows:
 - a. Labor. The costs of labor will be the actual cost for wages prevailing locally for each craft or type of worker at the time the Additional Work is done, plus employer payments of payroll taxes and insurance, health and welfare, pension, vacation, apprenticeship funds, and other direct costs resulting from federal, state or local laws, as well as assessment or benefits required by lawful collective bargaining agreements. The use of a labor classification which would increase the Additional Work cost will not be permitted unless the Contractor establishes the necessity for such additional costs. Labor costs for equipment operators and helpers shall be reported only when such costs are not included in the invoice for equipment rental.
 - b. Materials. The cost of materials reported shall be at the lowest current price at which such materials are locally available in the quantities involved, plus sales tax,

freight and delivery. Materials costs shall be based upon supplier or manufacturer's invoice.

- c. Tool and Equipment Use. Regardless of ownership, the rates to be used in determining equipment use shall not exceed listed rates prevailing locally at equipment rental agencies, or distributors, at the time the work is performed. The Contractor shall furnish cost data supporting the establishment of the rental rate. The rental rate to be applied for use of each items of equipment shall be the rate resulting in the least total cost to the City for the total period of use. The City shall the make the final determination as to an equitable rental rate for the equipment. No payment will be made for the use of small tools, which have a replacement value of \$1,000 or less.
- (i) The rental time to be paid for equipment shall be the time the equipment is in productive operation on the Additional Work being performed. Rental time will not be allowed while equipment is inoperative due to breakdowns.
 - (ii) All equipment shall, in the opinion of the City, be in good working condition and suitable for the purpose for which the equipment is to be used. Equipment with no direct power unit shall be powered by a unit of at least the minimum rating recommended by the manufacturer.
 - (iii) Before construction equipment is used on any Additional Work, the Contractor shall plainly stencil or stamp an identifying number thereon at a conspicuous location, and shall furnish to the City, in duplicate, a description of the equipment and its identifying number.
 - (iv) When hourly rates are listed, any part of an hour less than 30 minutes of operation shall be considered to be 1/2-hour of operation, and any part of an hour greater than 30 minutes will be considered one hour of operation. When daily rates are listed, any part of a day less than 4 hours operation shall be considered to be 1/2-day of operation.
- d. Allowed Mark-up. The allowed mark-up for any and all overhead (including supervision and home and field office costs) and profit on work added to the Contract shall be determined in accordance with the following provisions:
- (i) "Net Cost" is defined as the actual costs of labor, materials and tools and equipment only, excluding overhead and profit. The costs of applicable insurance and bond premium will be reimbursed to the Contractor and Subcontractors at cost only, without mark-up. Contractor shall provide the City with documentation of the costs, including but not limited to payroll records, invoices, and such other information as the City may reasonably request.
 - (ii) For Work performed by the Contractor's forces the allowed mark-up shall not exceed fifteen (15%) percent of labor costs, ten percent (10%) of material costs, and ten percent (10%) of the cost of tools and equipment use.
 - (iii) For Work performed by a Subcontractor, the added cost for overhead and profit shall not exceed fifteen percent (15%) of the Subcontractor's Net Cost of the

Work to which the Contractor may add up to five percent (5%) of the Subcontractor's Net Cost.

- (iv) For Work performed by a sub-subcontractor, the added cost for overhead and profit shall not exceed fifteen percent (15%) of the sub-subcontractor's Net Cost for Work to which the Subcontractor and Contractor may each add up to an additional five percent (5%) of the Net Cost of the lower tier subcontractor.
- (v) No additional mark-up will be allowed for lower tier subcontractors, and in no case shall the added cost for overhead and profit payable by the City exceed twenty-five percent (25%) of the Net Cost as defined herein, of the party that performs the Work.
- (vi) Calculation of the mark-up will be subject to the limitations above and to calculation as further detailed in (b)(B)(5) above.

e. Documentation of Time-and-Material Costs.

- (i) T&M Daily Sheets. Contractor must submit timesheets, materials invoices, records of equipment hours, and records of rental equipment hours to the City's for an approval signature each day that Work is performed on a time-and-material basis. The Engineer's, City Inspector's, or representative's signature on time sheets only serves as verification that the Work was performed and is not indicative of the City's agreement to Contractor's entitlement to the cost.
- (ii) T&M Summary Sheet. Contractor shall submit a T&M Summary Sheet, which shall include total actual costs, within five (5) Days following completion of Additional Work on a time-and-material basis. Contractor's total actual cost shall be presented in a summary table in an electronic spreadsheet file by labor, material, equipment, and any other costs, along with documentation supporting the costs. Contractor's failure to submit the T&M Summary Sheet within five (5) Days of completion of the Additional Work will result in Contractor's waiver for any reimbursement of any costs associated with the Additional Work.

f. Excluded Costs. The following costs or any other home or field office overhead costs, all of which are to be considered administrative costs covered by the Contractor's mark-up, shall not be allowed costs and shall not be included in any lump sum proposals or time-and-materials invoices:

- (i) Overhead Cost. Payroll costs and other compensation of Contractor's officers, executives, principals, general managers, engineers, architects, estimators, attorneys, auditors, accountants, purchasing and contracting agents, timekeepers, clerks, and other personnel employed by Contractor whether at the Site or in Contractor's principal office or any branch office, material yard, or shop for general administration of the Work;
- (ii) Office Expenses. Expenses of Contractor's principal and branch offices;
- (iii) Capital Expenses. Any part of Contractor's capital expenses, including interest on Contractor's capital employed for the Additional Work and charges against Contractor for delinquent payments;

- (iv) Negligence. Costs due to the negligence of Contractor or any Subcontractor or Supplier, or anyone directly or indirectly employed by any of them or for whose acts any of them may be liable, including without limitation the correction of Defective Work, disposal of materials or equipment wrongly supplied, and making good any damage to property;
- (v) Small Tools. Cost of small tools valued at less than \$1,000 and that remain the property of Contractor;
- (vi) Administrative Costs. Costs associated with the preparation of Change Orders (whether or not ultimately authorized), cost estimates, or the preparation or filing of Claims;
- (vii) Anticipated Lost Profits. Expenses of Contractor associated with anticipated lost profits or lost revenues, lost income or earnings, lost interest on earnings, or unpaid retention;
- (viii) Home Office Overhead. Costs derived from the computation of a "home office overhead" rate by application of the Eichleay, Allegheny, burden fluctuation, or other similar methods;
- (ix) Special Consultants and Attorneys. Costs of special consultants or attorneys, whether or not in the direct employ of Contractor, employed for services specifically related to the resolution of a Claim, dispute, or other matter arising out of or relating to the performance of the Additional Work.
- (x) Other. Other overhead or general expense costs of any kind and the cost of any item not specifically and expressly included in the Contract Documents; including but not limited to: submittals, drawings, field drawings, shop drawings, including submissions of drawings; field inspection; general superintendence; computer services; reproduction services; salaries of project engineer, superintendent, timekeeper, storekeeper, and secretaries; janitorial services; small tools, incidentals and consumables; temporary on-site facilities (offices, telephones, high speed internet access, plumbing, electrical power, lighting; platforms, fencing, water); surveying; estimating; protection of work; handling and disposal fees; final cleanup; other incidental work; related warranties; insurance and bond premiums.
- (xi) Compliance with Federal Cost Principles. If the Project is federally funded, any costs that are not allowable, reasonable and allocable to the Project, under generally accepted accounting principles and the applicable federal requirements.

9.2 Procedure for Resolving Claims.

Contractor shall timely comply with any and all requirement of the Contract Documents pertaining to notices and requests for changes to the Contract Time or Contract Price, including but not limited to all requirements of Article 9.1, as a prerequisite to filing any claim governed by this Article. The failure to timely submit a notice of delay or notice of change, or to timely request a change to the time for completion or Contractor's

compensation, or to timely provide any other notice or request required herein shall constitute a waiver of the right to further pursue the claim under the Contract or at law.

- A. Intent. Effective January 1, 1991, Section 20104 et seq., of the California Public Contract Code prescribes a process utilizing informal conferences, non-binding judicial supervised mediation, and judicial arbitration to resolve disputes on construction claims of \$375,000 or less. Effective January 1, 2017, Section 9204 of the Public Contract Code prescribes a process for negotiation and mediation to resolve disputes on construction claims. The intent of this Article is to implement Sections 20104 et seq. and Section 9204 of the California Public Contract Code. This Article shall be construed to be consistent with all applicable law, including but not limited to these statutes.
- B. Claims. For purposes of this Article, "Claim" means a separate demand by the Contractor for:
1. An adjustment to the time for completion including, without limitation, for relief from damages or penalties for delay assessed by the City;
 2. Payment by the City of money or damages arising from Work done by or on behalf of the Contractor pursuant to the Contract, payment for which is not otherwise expressly provided or to which the Contractor is not otherwise entitled; or
 3. An amount the payment of which is disputed by the City.

A "Claim" does not include any demand for payment for which the Contractor has failed to provide notice, request a Change Order, or otherwise failed to follow any procedures contained in the Contract Documents.

- C. Filing Claims. Claims governed by this Article may not be filed unless and until the Contractor completes any and all requirements of the Contract Documents pertaining to notices and requests for changes to the Contract Time or Contract Price, and Contractor's request for a change has been denied in whole or in part. Claims governed by this Article must be filed no later than thirty (30) Days after a request for change has been denied in whole or in part or after any other event giving rise to the Claim. The Claim shall be submitted in writing to the City and shall include on its first page the following words in 16 point capital font: "THIS IS A CLAIM." The Claim shall include the all information and documents necessary to substantiate the Claim, including but not limited to those identified below. Nothing in this Article is intended to extend the time limit or supersede notice requirements otherwise provided by Contract Documents. Failure to follow such contractual requirements shall bar any Claims or subsequent proceedings for compensation or payment thereon.
- D. Documentation. The Contractor shall submit all Claims in the following format:
1. Summary description of Claim including basis of entitlement, merit and amount of time or money requested, with specific reference to the Contract Document provisions pursuant to which the Claim is made
 2. List of documents relating to Claim:
 - a. Specifications

- b. Drawings
 - c. Clarifications (Requests for Information)
 - d. Schedules
 - e. Other
3. Chronology of events and correspondence
 4. Narrative analysis of Claim merit
 5. Analysis of Claim cost, including calculations and supporting documents
 6. Time impact analysis in the form required by the Contract Documents or, if the Contract Documents do not require a particular format, CPM format, if an adjustment of the Contract Time is requested
- E. City's Response. Upon receipt of a Claim pursuant to this Article, the City shall conduct a reasonable review of the Claim and, within a period not to exceed 45 Days, shall provide the Contractor a written statement identifying what portion of the Claim is disputed and what portion is undisputed. Any payment due on an undisputed portion of the Claim will be processed and made within 60 Days after the City issues its written statement.
1. If the City needs approval from its governing body to provide the Contractor a written statement identifying the disputed portion and the undisputed portion of the Claim, and the City's governing body does not meet within the 45 Days or within the mutually agreed to extension of time following receipt of a Claim sent by registered mail or certified mail, return receipt requested, the City shall have up to three (3) Days following the next duly publicly noticed meeting of the City's governing body after the 45-Day period, or extension, expires to provide the Contractor a written statement identifying the disputed portion and the undisputed portion.
 2. Within 30 Days of receipt of a Claim, the City may request in writing additional documentation supporting the Claim or relating to defenses or Claims the City may have against the Contractor. If additional information is thereafter required, it shall be requested and provided pursuant to this subdivision, upon mutual agreement of the City and the Contractor. The City's written response to the Claim, as further documented, shall be submitted to the Contractor within 30 Days (if the Claim is less than \$50,000, within 15 Days) after receipt of the further documentation, or within a period of time no greater than that taken by the Contractor in producing the additional information or requested documentation, whichever is greater.
- F. Meet and Confer. If the Contractor disputes the City's written response, or the City fails to respond within the time prescribed, the Contractor may so notify the City, in writing, either within 15 Days of receipt of the City's response or within 15 Days of the City's failure to respond within the time prescribed, respectively, and demand in writing an informal conference to meet and confer for settlement of the issues in dispute. Upon receipt of a demand, the City shall schedule a meet and confer conference within 30 Days for settlement of the dispute.
- G. Mediation. Within 10 business days following the conclusion of the meet and confer conference, if the Claim or any portion of the Claim remains in dispute, the City shall provide the Contractor a written statement identifying the portion of the Claim that remains

in dispute and the portion that is undisputed. Any payment due on an undisputed portion of the Claim shall be processed and made within 60 Days after the City issues its written statement. Any disputed portion of the Claim, as identified by the Contractor in writing, shall be submitted to nonbinding mediation, with the City and the Contractor sharing the associated costs equally. The public entity and Contractor shall mutually agree to a mediator within 10 business days after the disputed portion of the Claim has been identified in writing, unless the parties agree to select a mediator at a later time.

1. If the parties cannot agree upon a mediator, each party shall select a mediator and those mediators shall select a qualified neutral third party to mediate with regard to the disputed portion of the Claim. Each party shall bear the fees and costs charged by its respective mediator in connection with the selection of the neutral mediator.
 2. For purposes of this Article, mediation includes any nonbinding process, including, but not limited to, neutral evaluation or a dispute review board, in which an independent third party or board assists the parties in dispute resolution through negotiation or by issuance of an evaluation. Any mediation utilized shall conform to the timeframes in this Article.
 3. Unless otherwise agreed to by the City and the Contractor in writing, the mediation conducted pursuant to this section shall excuse any further obligation under Section 20104.4 to mediate after litigation has been commenced.
- H. Procedures After Mediation. If following the mediation, the Claim or any portion remains in dispute, the Contractor must file a Claim pursuant to Chapter 1 (commencing with Section 900) and Chapter 2 (commencing with Section 910) of Part 3 of Division 3.6 of Title 1 of the Government Code prior to initiating litigation. For purposes of those provisions, the running of the period of time within which a Claim must be filed shall be tolled from the time the Contractor submits his or her written Claim pursuant to subdivision (a) until the time the Claim is denied, including any period of time utilized by the meet and confer conference.
- I. Civil Actions. The following procedures are established for all civil actions filed to resolve Claims of \$375,000 or less:
1. Within 60 Days, but no earlier than 30 Days, following the filing or responsive pleadings, the court shall submit the matter to non-binding mediation unless waived by mutual stipulation of both parties or unless mediation was held prior to commencement of the action in accordance with Public Contract Code section 9204 and the terms of this Contract. The mediation process shall provide for the selection within 15 Days by both parties of a disinterested third person as mediator, shall be commenced within 30 Days of the submittal, and shall be concluded within 15 Days from the commencement of the mediation unless a time requirement is extended upon a good cause showing to the court.
 2. If the matter remains in dispute, the case shall be submitted to judicial arbitration pursuant to Chapter 2.5 (commencing with Section 1141.10) of Title 3 of Part 3 of the Code of Civil Procedure, notwithstanding Section 1114.11 of that code. The Civil Discovery Act of 1986 (Article 3 (commencing with Section 2016) of Chapter 3 of Title 3 of Part 4 of the Code of Civil Procedure) shall apply to any proceeding brought under this subdivision consistent with the rules pertaining to judicial arbitration. In addition to Chapter 2.5 (commencing with Section 1141.10) of Title 3 of Part 3 of the Code of Civil

Procedure, (A) arbitrators shall, when possible, be experienced in construction law, and (B) any party appealing an arbitration award who does not obtain a more favorable judgment shall, in addition to payment of costs and fees under that chapter, also pay the attorney's fees on appeal of the other party.

J. Government Code Claim Procedures.

1. This Article does not apply to tort claims and nothing in this Article is intended nor shall be construed to change the time periods for filing tort claims or actions specified by Chapter 1 (commencing with Section 900) and Chapter 2 (commencing with Section 910) of Part 3 of Division 3.5 of Title 1 of the Government Code.
2. In addition to any and all requirements of the Contract Documents pertaining to notices of and requests for adjustment to the Contract Time, Contract Price, or compensation or payment for Additional Work, disputed Work, construction claims and/or changed conditions, the Contractor must comply with the claim procedures set forth in Government Code Section 900, et seq. prior to filing any lawsuit against the City.
3. Such Government Code claims and any subsequent lawsuit based upon the Government Code claims shall be limited to those matters that remain unresolved after all procedures pertaining to adjustment of the Contract Time or Contract Price for Additional Work, disputed Work, construction claims, and/or changed conditions have been followed by Contractor. If Contractor does not comply with the Government Code claim procedure or the prerequisite contractual requirements, Contractor may not file any action against the City.
4. A Government Code claim must be filed no earlier than the date the Work is completed or the date the Contractor last performs Work on the Project, whichever occurs first. A Government Code claim shall be inclusive of all unresolved Claims known to Contractor or that should reasonably be known to Contractor excepting only new unrelated Claims that arise after the Government Code claim is submitted.

ARTICLE 10 - MEASUREMENT; PAYMENT

10.1 Cost Breakdown.

A. Lump Sum Work.

1. Contractor shall furnish on forms approved by the City within ten (10) Days of the Notice to Proceed, a schedule of values allocating the entire Contract Price to the various portions of the Work and prepared in such a form and supported by such data to substantiate its accuracy as the Engineer may require. This schedule of values, unless objected to by the Engineer, shall be used as a basis for reviewing the Contractor's applications for payment. Contractor shall submit the schedule of values prior to submitting its first application for payment, and the City will not issue any payment until it receives and approves the schedule of values.

B. Unit Price Work.

1. Where the Contract Documents provide that all or part of the Work is to be Unit Price Work, initially the Contract Price will be deemed to include for all Unit Price Work an

amount equal to the sum of the unit price for each separately identified item of Unit Price Work multiplied by the estimated quantity of each item as indicated in the Contract. The estimated quantities of items of Unit Price Work are not guaranteed and are solely for the purpose of comparison of Bids and determining an initial Contract Price. Each unit price will be deemed to include an amount considered by Contractor to be adequate to cover Contractor's overhead and or profit for each separately identified item.

2. Unless otherwise specified, payment will be based on the actual quantities of Work as verified and approved by the Engineer, based on the price per unit as set forth in the Bid. Any pending additions, reductions, and deletion of Proposal Item Quantities will be adjusted accordingly upon the completion of the project and tabulation of the "Final Contract Quantities" via a "Contract Quantity Adjustment Change Order" thereby adjusting the Final Contract Price and time accordingly, prior to formal Final Acceptance by the City. Adjusted quantity "overages" shall not be paid until after the contract quantities and amounts are officially adjusted via change order. Upon execution of the Quantity Adjustment Change Order, the contractor may bill for such adjusted quantities, less retention as applicable and provided for in these project Specifications.
3. The City or Contractor may initiate a Change Order or Change Order Request to adjust the Contract Price in accordance with Contractor Documents based on actual quantities of Unit Price Work. The City or Contractor may make a claim for an adjustment in the Unit Price in accordance with the Contract Documents if:
 - a. the quantity of any item of Unit Price Work performed by Contractor differs by twenty-five percent (25%) or more from the estimated quantity of such item indicated in the Contract; and
 - b. there is no corresponding adjustment with respect to any other item of Work; and
 - c. Contractor believes that Contractor is entitled to an increase in unit price as a result of having incurred additional expense or the City believes that the City is entitled to a decrease in unit price and the parties are unable to agree as to the amount of any such increase or decrease.

10.2 Progress Estimates and Payment.

- A. By the tenth (10th) Day of the following calendar month (or as approved by the City), Contractor shall submit to Engineer a payment request which shall set forth in detail the value of the Work done for the period beginning with the date Work was first commenced and ending on the end of the calendar month for which the payment request is prepared. Contractor shall include an adjusted list of actual quantities, verified by the Engineer/City, for unit price items listed, if any, in the Bid. Contractor shall include any amount earned for authorized Additional Work. Contractor shall certify under penalty of perjury, that all cost breakdowns and periodic estimates accurately reflect the Work on the Project.
- B. From the total thus computed, a deduction shall be made in the amount of five percent (5%) for retention. From the remainder a further deduction may be made in accordance with Section C below. The amount computed, less the amount withheld for retention and any amounts withheld as set forth below, shall be the amount of the Contractor's payment request.

- C. The City may withhold a sufficient amount or amounts of any payment or any payments otherwise due to Contractor, as in its judgment may be necessary to cover:
1. Payments which may be past due and payable for just claims against Contractor or any Subcontractors for labor or materials furnished in and about the performance of work on the Project under this Contract.
 2. Defective work not remedied.
 3. Failure of Contractor to make proper payments to his Subcontractor or for material or labor.
 4. Completion of the Contract if there is a reasonable doubt that the Work can be completed for balance then unpaid.
 5. Damage to another contractor or a third party.
 6. Amounts which may be due for claims against Contractor.
 7. Failure of Contractor to update or deliver "As-Built" Record Drawings to City.
 8. Failure to provide update on construction schedule as required herein.
 9. Site cleanup.
 10. Failure to comply with Contract Documents, Certified Payroll, or Prevailing Wage Requirements and set forth in the Project Documents or applicable regulations.
 11. Liquidated damages.
 12. Legally permitted penalties.
- D. The City may apply such withheld amount or amounts to payment of such claims or obligations at its discretion with the exception of subsections (C)(1), (3), and (5) of this Article, which must be retained or applied in accordance with applicable law. In so doing, the City shall be deemed the agent of Contractor and any payment so made by the City shall be considered as a payment made under contract by the City to Contractor and the City shall not be liable to Contractor for such payments made in good faith. Such payments may be made without prior judicial determination of claim or obligations. The City will render Contractor a proper accounting of such funds disbursed on behalf of Contractor.
- E. Upon receipt, the Engineer shall review the payment request to determine whether it is undisputed and suitable for payment. If the payment request is determined to be unsuitable for payment, it shall be returned to Contractor as soon as practicable but not later than seven (7) Days after receipt, accompanied by a document setting forth in writing the reasons why the payment request is not proper. The City shall make the progress payment within 30 Days after the receipt of an undisputed and properly submitted payment request from Contractor, provided that a release of liens and claims has been received from the Contractor pursuant to Civil Code section 8132. The number of days available to the City to make a payment without incurring interest pursuant to this paragraph shall be reduced by the number of Days by which the Engineer exceeds the seven (7) Day requirement.

- F. The City shall have the right to adjust any estimate of quantity and to subsequently correct any error made in any estimate for payment.

10.3 Final Acceptance and Payment

- A. Following the City's issuance of the Notice of Substantial Completion and prior to Final Formal Acceptance of the Work, the Contractor shall submit to the City a written statement of the final quantities of unit price items for inclusion in the final payment request. Upon verification and agreement of the "Final Contract Quantities" a "Contract Quantity Adjustment Change Order" will be issued to adjust the Final Contract Price and time accordingly, prior to formal Final Acceptance by the City. Adjusted quantity "overages" shall not be paid until after the contract quantities and amounts are officially adjusted via change order. Upon execution of the Quantity Adjustment Change Order, the contractor may bill for such adjusted quantities, less retention as applicable and provided for in these project Specifications. The City shall have the right to adjust any estimate of quantity and to correct any error made in any estimate for payment.
- B. When the Work has been accepted there shall be paid to Contractor a sum equal to the Contract Price less any amounts previously paid Contractor and less any amounts withheld by the City from Contractor under the terms of the Contract. The final five percent (5%), or the percentage specified in the Notice Inviting Bids where the City has adopted a finding of substantially complete, shall not become due and payable until as required by Public Contract Code section 7107. If the Contractor has placed securities with the City as described herein, the Contractor shall be paid a sum equal to one hundred percent (100%) of the Contract Price less any amounts due the City under the terms of the Contract.

Upon Formal Final Written Acceptance by the City, the City shall cause to be recorded in the office of the County Recorder a Notice of Completion. After thirty-five (35) days after recording Notice of Completion of the work involved in the Contract, the City will pay the Contractor in lawful money such sums of money as may be due the Contractor including all sums retained but excluding such sums as have previously been paid the Contractor. This payment will constitute the final payment to the Contractor under this Contract except for Maintenance and Plant Establishment Periods which will be billed on a monthly basis with no retention held.

- C. Unless Contractor advises the City in writing prior to acceptance of the final five percent (5%) or the percentage specified in the Notice Inviting Bids where the City has adopted a finding of completion, or the return of securities held as described herein, said acceptance shall operate as a release to the City of all claims and all liability to Contractor for all things done or furnished in connection with this Work and for every act of negligence of the City and for all other claims relating to or arising out of this Work. No payments, however, final or otherwise, shall operate to release Contractor or its sureties from the Faithful Performance Bond, Labor and Material Payment Bond, or from any other obligation under this Contract.
- D. In case of suspension of the Contract any unpaid balance shall be and become the sole and absolute property of the City to the extent necessary to repay the City any excess in the cost of the Work above the Contract Price.
- E. Final payment shall be made no later than 60 Days after the date of Final Formal Written Acceptance of the Work by the City or the date of occupation, beneficial use and enjoyment

of the Work by the City including any operation only for testing, start-up or commissioning accompanied by cessation of labor on the Work, provided that a release of liens and claims has been received from the Contractor pursuant to Civil Code section 8136. Unless such portions of the project are stipulated in the Project specifications to be staged in a manner that the City may take beneficial use of portions or areas of the project prior to completion and Final Acceptance of the entire project.

- F. Within ten (10) Days from the time that all or any portion of the retention proceeds are received by Contractor, Contractor shall pay each of its Subcontractors from whom retention has been withheld each Subcontractor's share of the retention received. However, if a retention payment received by Contractor is specifically designated for a particular Subcontractor, payment of the retention shall be made to the designated Subcontractor if the payment is consistent with the terms of the subcontract.

ARTICLE 11 - MISCELLANEOUS

11.1 Document Retention & Examination

- A. In accordance with Government Code section 8546.7, records of both the City and the Contractor shall be subject to examination and audit by the State Auditor General for a period of three (3) years after final payment.
- B. Contractor shall make available to the City any of the Contractor's other documents related to the Project immediately upon request of the City within the 3 year period.
- C. In addition to the State Auditor rights above, the City shall have the right to examine and audit all books, estimates, records, contracts, documents, Proposal documents, subcontracts, and other data of the Contractor (including computations and projections) related to negotiating, pricing, or performing the modification in order to evaluate the accuracy and completeness of the cost or pricing data at no additional cost to the City, for a period of four (4) years after final payment.

11.2 Notice.

- A. All notices shall be in writing and either served by personal delivery or mailed to the other party. Written notice to the Contractor shall be addressed to Contractor's principal place of business unless Contractor designates another address in writing for service of notice. Notice to the City shall be addressed to the City as designated in the Notice Inviting Bids unless the City designates another address in writing for service of notice. Notice shall be effective upon receipt or five (5) Days after being sent by first class mail, whichever is earlier. Notice given by facsimile shall not be effective unless acknowledged in writing by the receiving party.

11.3 Notice of Third Party Claims

- A. Pursuant to Public Contract Code section 9201, the City shall provide the Contractor with timely notification of the receipt of any third-party claims relating to the Contract. The City is entitled to recover reasonable costs incurred in providing such notification.

11.4 State License Board Notice

- A. Contractors are required by law to be licensed and regulated by the Contractors' State License Board which has jurisdiction to investigate complaints against contractors if a complaint regarding a patent act or omission is filed within four (4) years of the date of the alleged violation. A complaint regarding a latent act or omission pertaining to structural defects must be filed within ten (10) years of the date of the alleged violation. Any questions concerning a contractor may be referred to the Registrar, Contractors' State License Board, P.O. Box 26000, Sacramento, California 95826.

11.5 Assignment of Contract

- A. Contractor shall not assign, transfer, convey, sublet or otherwise dispose of the rights or title of interest of any or all of this contract without the prior written consent of the City. Any assignment or change of Contractor's name or legal entity without the written consent of the City shall be void. Any assignment of money due or to become due under this Contract shall be subject to a prior lien for services rendered or material supplied for performance of Work called for under the Contract Documents in favor of all persons, firms, or corporations rendering such services or supplying such materials to the extent that claims are filed pursuant to the Civil Code, the Code of Civil Procedure or the Government Code.

11.6 Change In Name And Nature Of Contractor's Legal Entity.

- A. Should a change be contemplated in the name or nature of the Contractor's legal entity, the Contractor shall first notify the City in order that proper steps may be taken to have the change reflected on the Contract and all related documents. No change of Contractor's name or nature will affect the City's rights under the Contract, including but not limited to the bonds.

11.7 Prohibited Interests

- A. No City official or representative who is authorized in such capacity and on behalf of City to negotiate, supervise, make, accept, or approve, or to take part in negotiating, supervising, making, accepting, or approving any engineering, inspection, construction or material supply contract or any subcontract in connection with construction of the project, shall be or become directly or indirectly interested financially in the Contract.

11.8 Controlling Law

- A. Notwithstanding any subcontract or other contract with any subcontractor, supplier, or other person or organization performing any part of the Work, this Contract shall be governed by the law of the State of California excluding any choice of law provisions.

11.9 Jurisdiction; Venue

- A. Contractor and any subcontractor, supplier, or other person or organization performing any part of the Work agrees that any action or suits at law or in equity arising out of or related to the bidding, award, or performance of the Work shall be maintained in the Superior Court of Riverside County, California, and expressly consent to the jurisdiction of said court, regardless of residence or domicile, and agree that said court shall be a proper venue for any such action.

11.10 Cumulative Remedies.

- A. The duties and obligations imposed by these General Conditions and the rights and remedies available hereunder to the parties hereto are in addition to and are not to be construed in any way as a limitation of, any rights and remedies available to any or all of them which are otherwise imposed or available by Applicable Laws, by special warranty or guarantee, or by other provisions of the Contract Documents. The provisions of this Article will be as effective as if repeated specifically in the Contract Documents in connection with each particular duty, obligation, right, and remedy to which they apply.

11.11 Survival of Obligations.

- A. All representations, indemnifications, warranties, and guarantees made in, required by, or given in accordance with the Contract Documents, as well as all continuing obligations indicated in the Contract Documents, will survive final payment, completion, and acceptance of the Work or termination or completion of the Contract or termination of the services of Contractor.

11.12 Headings.

- A. Article and paragraph headings are inserted for convenience only and do not constitute parts of these General Conditions.

11.13 Assignment of Antitrust Actions

- A. In accordance with §7103.5(b) of the California Public Contract Code, Contractor and Subcontractors must conform to the following requirements:
 - 1. In entering into a public works contract or a subcontract to supply goods, services, or materials pursuant to a public works contract, Contractor or Subcontractor offer and agree to assign to the awarding body all rights, title, and interest in and to all causes of action it may have under §4 of the Clayton Act (15 U.S.C. Sec. 15) or under the Cartwright Act (Chapter 2 (commencing with §16700) of Part 2 of Division 7 of the Business and Professions Code) arising from purchases of goods, services, or materials pursuant to the public works contract or the subcontract.
 - 2. This assignment must be made and become effective at the time the awarding body tenders to Contractor, without further acknowledgment by the parties.

11.14 All Legal Provisions Included

- A. Contractor shall give all notices and comply with all federal, state, and local laws, ordinances, rules, and regulations bearing on conduct of work as indicated and specified by their terms. References to specific laws, rules or regulations in this Contract are for reference purposes only and shall not limit or affect the applicability of provisions not specifically mentioned. If Contractor observes that drawings and specifications are at variance therewith, he shall promptly notify City in writing and any necessary changes shall be adjusted as provided for in this Contract for changes in Work. If Contractor performs any Work knowing it to be contrary to such laws, ordinances, rules, and regulations, and without such notice to City, he shall bear all costs arising therefrom.

- B. Contractor shall be responsible for familiarity with the Americans with Disabilities Act (“ADA”) (42 U.S.C. § 12101 et seq.). The Work will be performed in compliance with ADA laws, rules, and regulations. Contractor shall comply with the Historic Building Code, including, but not limited to, as it relates to the ADA, whenever applicable.
- C. Contractor acknowledges and understands that pursuant to Public Contract Code section 20676, sellers of "mined material" must be on an approved list of sellers published pursuant to Public Resources Code section 2717(b) in order to supply mined material for this Contract.
- D. No City official or representative who is authorized in such capacity and on behalf of City to negotiate, supervise, make, accept, or approve, or to take part in negotiating, supervising, making, accepting, or approving any engineering, inspection, construction or material supply contract or any subcontract in connection with construction of the Work, shall be or become directly or indirectly interested financially in the Contract.
- E. All provisions of law required to be inserted in the Contract or Contract Documents pursuant to any Applicable Laws shall be and are inserted herein. If through mistake, neglect, oversight, or otherwise, any such provision is not herein inserted or inserted in improper form, upon the application of either party, the Contract or Contract Documents shall be changed by City, at no increase in Contract Price or extension in Contract Times, so as to strictly comply with the Applicable Laws and without prejudice to the rights of either party hereunder.

END OF SECTION

SPECIAL PROVISIONS

1.0 GENERAL

1.1 Scope of Services

It shall be the contractor's responsibility to provide and furnish all materials, tools, labor, and incidentals to complete the work as outlined in the Project Description and as shown in the Contract Documents for **FY 2023-26 On-Call Striping Contract, City Project No. 083122 "Project"**.

It shall be the Contractor's responsibility to thoroughly review the project area, familiarize himself with the scope of proposed work and submit the proposal for the work accordingly.

1.2 Project Description

In general, the project consists of on-call striping services. The budget for FY 2022-23 is \$120,000.

All project work and incidental items to complete the project shall be performed in accordance with the plans, specifications, and other provisions of the contract. All the above improvements are to be constructed in a workmanlike manner, leaving the entire project in a neat and presentable condition resulting in a fully complete, operational, and functional product.

1.3 Cooperation with Other Contractors

Section 7-7 of the Standard Specifications is amended by the addition of the following provisions:

Should the Contractor foresee any interference, or believe project delays or problems might occur due to any action of any other contractor, or if the Contractor determines his own work may cause a delay to the work of the other contractors, the Contractor shall bring this to the attention of the Engineer as soon as possible so that the potential problems or delays may be worked out before problems arise. It is the intention of these Specifications that the Contractor shall cooperate as needed to effect this purpose, and shall be prepared to make short delays, to redeploy its work force to other parts of the work or project, to temporarily reschedule work, and take other reasonable actions to minimize interference and maximize cooperation with all other parties working within the project area.

If the Contractor maintains that he is unable to reasonably cooperate with others, then the Contractor shall be prepared to verify to the satisfaction of the City that there are no reasonable actions which he could take to cooperate with others, and that if he did, such actions would cause serious financial harm or unreasonable delay to the Contractor. If the City finds that such evidence is unsatisfactory, the City may order the Contractor to take whatever reasonable actions the City determines are necessary to provide the needed cooperation in order to meet the intent of these Specifications.

The contractor shall have no claim for extra compensation for any delay or costs if his work is held up, delayed or interrupted by the City's having to order cooperative work measures or schedule priorities as outlined above. An extension of contract time shall be the only compensation granted.

2.0 BID ITEMS

The bid items presented in the proposers schedule are intended to indicate major categories of the work for purposes of comparative bid analysis and payment breakdown for monthly progress payments. Bid items are not intended to be exclusive descriptions of work categories. The

Contractor shall determine and include in its pricing, all materials, labor, and equipment necessary to complete each bid item associated appurtenant work.

Those items for which there is no estimated quantity and/or specific pay item shall be completed in workmanship like manner to the satisfaction of the City. Work that is specified for which there is no bid item shall be considered incidental to work associated with bid items; therefore, the payment for these items shall be considered included in the various items of work for which a specific bid item has been provided.

3.0 MATERIALS

3.1 General

Whenever a material, article or piece of equipment is identified on the drawings or specified by reference to brand name or catalog number, it shall be understood that this is referenced for the purpose of defining the performance or other salient requirements and that other products of equal capacities, quality and function shall be considered.

3.2 Substitutions

The Contractor may recommend the substitution of a material, article, or piece of equipment of equal substance and function for those referred to in the Contract Documents by reference to the brand name or catalog number and, if in the opinion of the City, such material, article, or piece of equipment is of equal substance and function to that specified, the City may approve its substitution and use by the Contractor. Any cost differential shall be deductible from the Contract Price and the Contract Documents shall be appropriately modified by Change Order. The Contractor warrants that if substitutes are approved, no major changes in the function or general design of the project will result. Incidental changes or extra component parts required to accommodate substitute will be made by the Contractor without a change in the Contract Price or Contract time.

3.3 Storage

Materials and equipment shall be so stored as not to create a public nuisance and to insure the preservation of their quality and fitness for the work.

4.0 WORK DETAILS

4.1 Traffic Control & Site Protection

Unless otherwise approved, the Contractor shall provide a traffic control plan and a site protection plan, for acceptance by the City no later than five (5) working days after issuance of the Notice of Award. Subsequently, comments and corrections shall be returned to the Contractor within Fifteen (15) working days unless otherwise stated by the City. The traffic control/site protection plan shall conform to the following requirements listed in this section:

Traffic controls, including but not limited to, vehicular and pedestrian traffic controls, maintenance of vehicular and pedestrian access, detours, and street closures shall be in accordance with Subsection 7-10 of the latest edition of the "Standard Specifications for Public Works Construction," including all its subsequent amendments, CAMUTCD, and the latest edition of the "Work Area Traffic Control Handbook."

In the event of conflict, the Special Provisions shall take precedence over the 2014 CAMUTCD Revision 5. The 2014 CAMUTCD Revision 5 shall take precedence over the plans, and the plans shall take precedence over the "Standard Specifications."

Traffic control and the traffic plan shall conform to the following:

- a. The traffic control plan shall indicate the traffic control/site protection requirements for the different types of work to be performed. The Contractor shall be responsible for the preparation of plans as necessary for specific items of work. These plans shall be approved by the City prior to the Contractor commencing any work.
- b. All traffic control/site protection, and safety devices, equipment and materials, including but not limited to, fencing, cones, delineators, flashing warning lights, barricades, high level warning devices (flag trees), flags, signs, markers, portable barriers, flashing arrow signs, electronic changeable message signs and markings shall be provided and maintained in "like new" condition. Traffic control devices and device maintenance shall be to the satisfaction of the City.
- c. Changeable Message Sign Boards (CMS Boards) shall be installed at the jobsite as directed by the Public works Inspector. Boards shall be maintained in place until directed to remove said boards by the Public Works Inspector.
- d. Portable Changeable Message Signs (PCMS) are required for this project. A minimum of one (1) PCMS is required in each direction in advance of each work area as identified by the City. They shall be placed two (2) weeks in advance of the start of work and maintained throughout the construction window unless otherwise approved by the City. Total count is dependent on Contractor's proposed staging plan. A PCMS can be reused at a different location once the work is complete in that stage or as approved by the City.
- e. The Contractor shall furnish and properly install, construct, erect, use, and continuously inspect and maintain, twenty-four (24) hours per day, seven (7) days a week, all said devices, equipment and materials and all temporary and permanent pedestrian and driving surfaces as necessary to provide for the site safety and convenience of, and to properly warn, guide, control, regulate, channelize, and protect the vehicular traffic, pedestrian traffic, project workers, and the public throughout the entire limits of the work activity and beyond said limits as necessary to include area affecting or affected by the work, from the start of work to the formal completion of the work, or as directed/approved by the City.
- f. High-level warning devices (flag trees) are required at all times for any work being performed within the roadway unless otherwise specifically authorized by the City. **All barricades utilized for night work, long term, or 24-hour closures, shall be equipped with a flashing beacon and shall be maintained in an operational condition at all times.** All traffic cones shall be no less than twenty-eight (28) inches in height. **Only 48" tall portable reflective post delineators may be used for nighttime use, operations & closures, after-hours, weekends, Holidays, and/or long term closures, unless otherwise approved by the City.**
- g. Except as otherwise directed, as shown in the approved traffic control plan, and/or authorized by the City, two-way vehicular traffic shall be maintained at all times within a minimum of two, 12-foot-wide lanes, unless otherwise noted on the plans. At no time shall the Contractor be allowed to reduce the traveled way to one-way vehicular traffic without prior approval by the City. The Contractor will be required to prepare and provide a detail construction staging / traffic control plan for each phase of the project, in conformance with the staging plans provided in the construction plans.

- h. No reduction of the traveled way width shall be permitted between the hours of 8:00 a.m. and 4:00 p.m., unless otherwise shown in the approved traffic control plans, or prior authorization to do so is granted by the City. No lane closures shall be permitted or allowed on any City street before 8:00 a.m. and after 4:00 p.m., unless otherwise shown in the approved traffic control plans, or unless authorization to do so is granted by the City. No reduction of traveled way width shall be permitted on any City street before 8:00 a.m. or after 4:00 p.m., on weekends or holidays, or when active work is not being done, unless otherwise shown in the approved traffic control plans, or unless prior authorization to do so is granted by the City.

Except as shown in the approved traffic control plans, if traffic lanes are not kept open for public use on the days, at the times, and in the manner specified, damage will be sustained by the City and its residents. **Since it is and will be impracticable to determine the actual damage which the City and its residents will sustain by reason of Contractor's failure to comply with the special provisions outlined herein, the City and Contractor agree that Contractor will pay to the City the sum of \$200 per hour for each and every hour that any traffic lane is not kept open for public use as required by these special provisions, not as a penalty, but as predetermined liquidated damages.** The Contractor agrees to pay such liquidated damages as are provided for in this paragraph, and in case the same are not paid, Contractor agrees that City may deduct the amount of such liquidated damages from any money that is due or that may be due the Contractor under the contract.

- i. Access to vacant unused property may be restricted at the Engineer's discretion. Both vehicular and pedestrian access shall be maintained at all times to all properties except as otherwise specifically authorized in writing by the City Engineer. Contractor shall provide proof of written permission to use any and all adjacent properties. Contractor shall leave the site in a clean and stabilized condition equal to, or better than it was before. Contractor shall provide the City with written proof and release of liability for the site, and shall hold harmless the City for any claims, lawsuits, hazards, costs, etc., associated with their use of the property. Site restoration, stabilization, and cleanliness shall be to the satisfaction of the City.
- j. Any traffic control and site safety devices and equipment being used which becomes damaged, destroyed, faded, soiled, misplaced, worn out, inoperative, lost, or stolen shall be promptly repaired, refurbished and/or replaced. Any traffic control and site safety devices and equipment being used which are displaced or not in an upright position from any cause, shall be immediately and properly returned or restored to their proper position to the satisfaction of the City.
- k. Prior to the start of each work day, the Contractor verify the proper installation and restore or reset any and all traffic control and site safety devices that have been knocked over or are not in the proper position. The contractor shall perform all necessary work incidental to and commensurate with the proper signing, detouring, barricading, etc., required for that particular day's schedule of operations, and for the safety of overnight and weekend hours. No construction shall be permitted until such restoration, signing, and detouring operations have been completed.
- l. The contractor shall not park or store equipment near the traveled roadways or parkways unless otherwise approved by the City.
- m. An obstructed view of all signs and warning devices including but not limited to stop signs, stop ahead signs, street name signs, and other regulatory, warning and construction signs, markers, and warning devices shall be maintained at all times. No trucks or other equipment or materials shall be stopped, parked, or otherwise placed so as to obscure said signs, markers and devices from the view of vehicular and/or pedestrian traffic to which it applies.

- n. When entering or leaving roadways carrying public traffic, the Contractor's equipment, whether empty or loaded, shall yield to said public traffic at all times, except where the traffic is being controlled by police officers, fire officers or traffic signalized intersections.
- o. Stockpiling and/or storage of materials on any public right-of-way or parking areas will not be allowed without specific permission of the City Engineer. Materials spilled on or along the road, haul route, or adjacent areas, shall be immediately removed by mechanical or manual sweeping or cleaning, and to the satisfaction of the City. All stockpiled or stored materials stored in the street, right-of-way, or parking areas, shall be kept in a safe, neat, clean, and orderly fashion. All material stored in the street, parkway, or parking lot shall be moved or removed from said area immediately and prior to spreading or distributing to specific or final locations on the site. The storage area shall be cleaned and restored to equal or better than original condition upon completion of the work, and to the satisfaction of the City.
- p. At the end of each work period, as necessary, or as directed by City, excavations outside the court area shall be back-filled and patched with hot mix or cold mix asphalt as approved or directed by the City. Asphalt patches shall be installed and maintained to the satisfaction of the City. The Contractor will not be allowed to excavate a larger quantity of the roadway than he can successfully repave in the same working day. All lanes and parking areas shall be opened to traffic at the end of each working day unless otherwise approved by the City.
- q. The entire construction zone including all approaches to the construction/site safety zone shall be properly protected and contain advance warning devices and signage as applicable and in accordance with the CAMUTCD and WATCH Manual. All traffic control and site safety zones, and approaches shall be cleaned and maintained daily to the satisfaction of the City.
- r. When work has been completed on a particular street or has been suspended or rescheduled, and said street is to be opened to vehicular traffic, all equipment, "NO PARKING" signs, other obstruction, and necessary traffic control devices and equipment shall be promptly removed from that street except as otherwise authorized or directed by the City Engineer.
- s. Should the Contractor be neglectful, negligent, or refuse, fail, or otherwise be unavailable to promptly, satisfactorily, and fully comply with the provisions specified and referred to herein above, the City reserves the right to correct and/or mitigate any situation, which in the sole opinion of the City's Engineer constitutes a serious deficiency and/or serious case of noncompliance, by any means at its disposal including but not limited to; hiring a Traffic Control/Site Protection Company to implement or restore the required missing or damaged traffic control/site protection devices at the Contractor's and/or permittee's expense, and will deduct the cost therefore from the Contractor's progress and/or final payments. Such corrective action taken by the City shall not reduce or abrogate the Contractor's legal obligations and liability for proper traffic control and safety measures and shall not serve to transfer said obligations and liabilities from the Contractor to the City or the City's agents.
- t. Violations of any of the above provisions and/or provisions of the referenced publications, unless promptly and completely corrected to the satisfaction of the City Engineer, shall, at the sole discretion of the City, be grounds for termination of the Contract, or shutdown or partial shutdown of the work, without compensation to the Contractor and/or permittee, or liability to the City, all as prescribed by contractual obligation or State law, whichever is applicable.

4.2 The compensation for furnishing, placing, maintaining and removing traffic cones, telescoping tree flags, advance warning signs, electronic changeable message signs (CMS), barricades, temporary striping, and all other safety devices as required for public safety or as directed by the City,

shall be considered full compensation for all labor and materials for complying with these requirements, and no additional compensation will be made therefore.

4.3 Dust Control

The Contractor must comply with the City of Coachella's Municipal Code and the South Coast Air Quality Management District (SCAQMD) Regulations. Dust generated by traffic, Contractor's operations, or wind are all included in the definition of dust. The Contractor shall be responsible for watering the work area where dust is generated from traffic, contractor's operations, wind or other disturbances. Contractor's area of operations includes all disturbed areas and areas outside of roadbed or trench limits where excavation, saw-cutting, fill, or stockpiling of dirt or debris has taken place. The Contractor is responsible for monitoring all of the above-described areas in the project area during the life of the project, including after-hours, holidays, and weekends.

The Contractor shall prepare for review and approval by the City, the required PM-10 Best Management Practices (BMP's) plan. The plan shall be prepared in accordance with South Coast Air Quality Management District guidelines. The Contractor shall have a designated person Certified by the SCAQMD to prepare the PM-10 BMP's plan and oversee the approved dust control BMP's measures. Dust control shall include, but is not limited to the following:

- 1) Maintain dust control at all times by watering, including developing a water supply, and furnishing and placing all water required for work done in the contract.
- 2) Provide means to prevent track out onto public streets.
- 3) Provide street sweeping of material tracked onto public streets.
- 4) Utilizing wet-sawing techniques for concrete cutting and removals

All dust control measures, devices, stabilizers, and stabilization are subject to City approval and shall be to the satisfaction of the City.

4.4 Water

The Contractor shall make arrangements with the Coachella Water Agency to obtain water from designated fire hydrants at or near the project for use in dust control. It shall be the responsibility of the contractor to pay for the water and any deposits required. The cost to furnish and apply water shall be included in the unit prices for the various items bid and no additional payment will be allowed, therefore. Contractor shall maintain all water connections in a safe and leak-free condition satisfactory to the City.

4.5 Permits, Licenses and Inspection Fees

The Contractor shall obtain and pay for all costs incurred for permits, licenses and inspection fees required by other agencies because his operations. Prior to starting any work, the Contractor shall be required to have a City of Coachella Business License for the life of the contract; his subcontractors shall also have Business Licenses for the time they are engaged in work. **The Contractor will be responsible to obtain a "No-Cost" Encroachment Permit for all work done in the project/City limits.**

4.6 Air Contaminants

The Contractor shall not discharge smoke, dust or any other air contaminants into the atmosphere in such quantity as will violate the regulations of any legally constituted authority.

Without limiting the foregoing, Contractor must fully comply with all applicable laws, rules and regulations in furnishing or using equipment and/or providing services, including, but not limited to, emissions limits and permitting requirements imposed by the Air Quality Management District with jurisdiction over the Project and/or California Air Resources Board (CARB). Contractor shall

specifically be aware of the application of these limits and requirements to "portable equipment", which definition includes any item of equipment with a fuel-powered engine. Contractor shall indemnify the City against any fines or penalties imposed by the air quality management district, CARB, or any other governmental or regulatory agency for its violations of Applicable Laws as well as those of its subcontractors or others for whom Contractor is responsible under its indemnity obligations provided for in the Contract Documents.

4.7 Notification

Unless otherwise approved by the City, the Contractor shall notify in person and with printed notification (in English and Spanish language), at least seven (7) working days prior to commencing work, to all agencies, firms, institutions, postal service, residents, hospital, SunLine Transit Agency, schools, stores, utilities and waste disposal services, adjacent to, fronting, or affected by the work. Additional printed notification (in English and Spanish language) shall be given not less than seventy-two (72) hours prior to performing any work which will restrict property access, close or partially close the street, or which will restrict or disallow street parking.

All schools, churches, trash, delivery services, mail, and emergency services shall receive seven (7) working days written notification prior to performing any work which will restrict property or road access. The Contractor shall cooperate with local authorities relative to handling traffic through the area including coordinating with trash collection, school bus schedules, public transportation and emergency services.

The written notice will be approved by the City prior to issuance and shall include at least the following information: brief description of the improvements, the name, address and phone number of the Contractor, and the date and time work is to begin and finish. Contractor shall update and repost the information in the event the work delayed.

END OF SPECIAL PROVISIONS

TECHNICAL SPECIFICATIONS

The following Standard Specifications shall govern the work for this project. All language in the Standard Specifications shall remain in full force and effect, unless the language in the prevailing Contract Document specifically cites the section number in the Standard Specification and says said provision is in lieu of that Standard Specification section.

City of Coachella Standard Specifications and Procedures (June 2007)
City of Coachella Standard Infrastructure Drawings (2007 Edition) including Surface Improvement Standards and Water Standards
Standard Specifications for Public Works Construction "Greenbook" (2021), Except Section 1-9
Standard Plans for Public Works Construction "Greenbook" (2021)
Caltrans Standard Specifications (2021), except Division 1
Caltrans Standard Plans (2021)

PROPOSAL ITEM DESCRIPTIONS AND UNIT PRICE PAYMENT DESCRIPTIONS

1.0 Mobilization

Mobilization shall consist of preparatory work and operations, including, but not limited to, those necessary for the movement of personnel, equipment, supplies, and incidentals to the project site; for the establishment of all offices, buildings, staging areas and other facilities necessary for work on the project; and for all other work and operations which must be performed or costs incurred prior to beginning work on the various contract items on the project site; and for obtaining permits, insurance, and bonds as required for the proper performance and completion of the work. Payment for procuring and maintaining a staging area is included in the Bid Item entitled "Mobilization"/"Night Work Mobilization". This item includes any de-mobilization and re-mobilization that may be required for completing various stages or work or for the suspension of work.

2.0 SWPPP / BMPs

- a. Dust control BMPs. Dust control shall be paid for under Best Management Practices at the lump sum (LS) price as shown on the bid schedule.
- b. Storm Water Pollution Prevention BMP's Plan. Storm Water Pollution Prevention BMP's Plan shall conform to the provisions in Section 3-12.6, "Water Pollution Control" and Section 3-12.6.3 "Storm Water Pollution Prevention Plan (SWPP) of the California Regional Water Quality Control Board Colorado River Basin Region Discharge Requirements (Order No. R7-2008-0001, NPDES No. CAS617002) and the City of Coachella Standards.

The Contractor will need to prepare and submit to the City the Stormwater BMP's Plan document within five (5) working days after receiving Notice to Proceed unless otherwise approved by the City. The City will review the document within ten (10) working days unless stated otherwise. Contractor shall be ready to implement approved BMP's measures prior to mobilization to the site.

Storm Water Pollution Prevention BMP's Plan shall be paid for under the Dust Control/Stormwater Best Management Practices (BMP's) bid item as a lump sum (LS) price as shown on the bid schedule. All Storm Water Management, PM-10/Dust Control measures and BMP;s shall be to the satisfaction of the City.

3.0 Traffic Control Plan

The contract unit price shall include full compensation for pedestrian and traffic control. Work associated with pedestrian and traffic control shall include all planning, drafting of plans, costs for labor, materials, equipment and incidentals necessary to provide construction area signs, temporary traffic control including, but not limited to, lane closures and rerouting and other measures to control and maintain traffic during daily operations. Flaggers are a requirement of pedestrian and traffic control. Full compensation for traffic control systems include all costs to maintain traffic by placing and removing temporary signs, striping, flaggers, cones, barricades, etc., as specified in the Standard Specifications of the State of California, and as directed by the City, and no additional compensation will be allowed thereof.

4.0 Removal of Striping, Markings and Reflectors

c. Method of Measurement Removal of striping will be measured per linear foot (LF) along the line of the traffic stripe, without deductions for gaps in broken traffic stripes. For traffic stripe details requiring multiple lines, the composite section will count as a lineal foot of striping for payment, not the total length of the individual component lines. For a mix of striping and reflectors, the cost to remove reflectors shall be included in the removal. Measurement will be performed in the field by the Contractor upon completion and checked by the City. Removal of any type of pavement marking will be measured per square foot (SF) removed. The quantity of square footage for specific pavement markings shall be what is indicated in the most recent version of the Caltrans Standard Plans.

d. Thermoplastic Removal. Traffic stripe and pavement markings shall be removed at the locations requested and as directed by the City. The Contractor shall submit a written work plan for the removal, storage, and disposal of thermoplastic and painted traffic stripes and pavement markings to the Project Manager for approval not less than five (5) days prior to the start of removal operations. Removal operations shall not begin until the Project Manager has approved the work plan. Where grinding or other methods approved by the Project Manager are used to remove thermoplastic and painted traffic stripes and pavement markings, the removed residue, including dust, shall be contained and collected immediately. Sweeping equipment shall not be used. Collection shall be by high efficiency particulate air (HEPA) filter equipped vacuum attachment operated concurrently with the removal operations or other equally effective methods approved by the Project Manager.

e. Payment. The contract unit price paid per linear foot or square foot for removal of striping, markings and reflectors shall include full compensation for furnishing all labor, materials, tools, equipment and incidentals, and for doing all the work for removal, providing storage and disposal of removed material, and for providing personnel protective equipment, training, air monitoring, and medical surveillance and incidentals and no additional or separate compensation will be made thereof.

Full compensation for removal and disposal of raised pavement markers, thermoplastic striping, and thermoplastic markings shall be considered as included in the contract unit price paid for "Remove Striping and Markings" and shall include full compensation for furnishing all labor, materials, tools, equipment and incidentals and for doing the work involved removing and disposal of materials, and no separate payment will be made thereof.

5.0 Painting of Striping, Markings and Reflectors

a. Method of Measurement Painting of striping or standard Details will be measured per linear foot (LF) along the line of the traffic stripe, without deductions for gaps in broken traffic stripes. For traffic stripe details requiring multiple lines, the composite section will count as a lineal foot of striping for payment, not the total length of the individual component lines. For a mix of striping and reflectors, the cost to install reflectors shall be included in the painting. Measurement will be performed in the field by the Contractor upon completion and checked by the City.

Painting of any type of pavement marking will be measured per square foot (SF) painted. The quantity of square footage for specific pavement markings shall be what is indicated in the most recent version of the Caltrans Standard Plans.

b. Materials. Contractor shall use durable, high skid resistant, retroreflective pavement marking material suitable for use as interstate shields, route shields, bike path, roadway, intersection, airport, commercial or private pavement delineation and markings. Materials shall conform to the provisions in Section 84-2.02 "Materials" of the State Standard Specifications. All traffic striping and pavement markings shall be two coats of paint with glass beads in each coat, unless otherwise approved by the City. A minimum of 7 days and a maximum of 14 days shall elapse between the second coats of paint. Refresh Striping of existing painted striping or markings shall consist of 1 coat of paint with glass beads. Unless otherwise specified or approved, existing Thermoplastic stripes or markings shall be completely removed and then replaced with 2 coats of paint with glass beads in each coat. A minimum of 7 days and a maximum of 14 days shall elapse between application of the first and second coats of paint.

The paint for traffic striping and markings shall be as follows:

1. High Performance Water Borne, Rapid Dry, White – PERVO Paint Co. #6000 or approved equal.
2. High Performance Water Borne, Rapid Dry, Black – PERVO Paint Co. #6002, or approved equal.
3. High Performance Water Borne, Rapid Dry, Black – PERVO Paint Co. #6001, or approved equal.

Crosswalk lines, stop limit lines, stop legends, speed hump legends and chevrons, triangles, arrows, etc. shall be considered as pavement markings.

All paint shall meet SCAQMD Rule 1113.

Glass beads shall be applied with each coat of paint, and shall conform to State Specification 8010-21C-22 (Type II).

Pavement markers shall conform to the provisions in Section 85 "Pavement Markers" of the State of California Standard Specifications and as approved by the City.

c. Layout. All layout and cat tracking shall be performed by and at the expense of the contractor, and shall be approved by the City prior to placement of final striping or markings. Striping and marking shall be done at locations of existing striping and marking,

except as modified by the City. Advance spotting and recording of angle points, end points, and other control points, plus color and line detail type, shall be performed by the Contractor. Any uncertainties shall be discussed with City prior to application.

d. Payment The contract unit price paid per linear foot, each, or square foot for painting of striping and markings shall include full compensation for furnishing all labor, materials, tools, equipment and incidentals, and for doing all the work involved in applying painted traffic stripes, pavement markers, complete in place, including any necessary cat tracks, dribble lines, alignment for stripes, layout work and temporary traffic stripes and pavement markers, and as directed by the City and no additional compensation will be made thereof.

6.0 Installation of Green Bike Markings (Methyl Methacrylate Marking)

a. Method of Measurement “Installation of Green Bike Markings (Methyl Methacrylate Marking)” will be measured per square foot (SF) along the edges of the marking. Measurement will be performed in the field by the Contractor upon completion and checked by the City.

b. Materials. MMAX Bike Lane Areas shall conform to the provisions in Section 84-1 “General” and 84-2 “Traffic Stripes and Pavement Markings,” of the State Standard Specifications and these special provisions.

The Contractor shall furnish the necessary control points for all striping and markings and shall be responsible for the completeness and accuracy thereof to the satisfaction of the City. The work shall include all preparation, mixing, application of Methyl Methacrylate Bike Lane Treatment System, Green – CycleGrip MMAX (or approved equal), curing time. Contractor shall submit product MSDS and Cut sheets upon award or as approved by the City.

c. Payment The contract unit price paid per square foot for green bike markings (methyl methacrylate marking) shall include full compensation for furnishing all labor, materials, tools, equipment and incidentals, and for doing all the work involved in applying the green bike markings (methyl methacrylate marking), complete in place, including any necessary cat tracks, dribble lines, alignment, layout work and temporary markings and as directed by the City and no additional compensation will be made thereof.

END OF SECTION

APPENDIX A - STANDARD DRAWINGS

COC Std. S-1 Express Way

COC Std. S-2 Major Arterial

COC Std. S-3 Minor Arterial

COC Std. S-4 Major Collector

COC Std. S-5 Minor Collector Residential

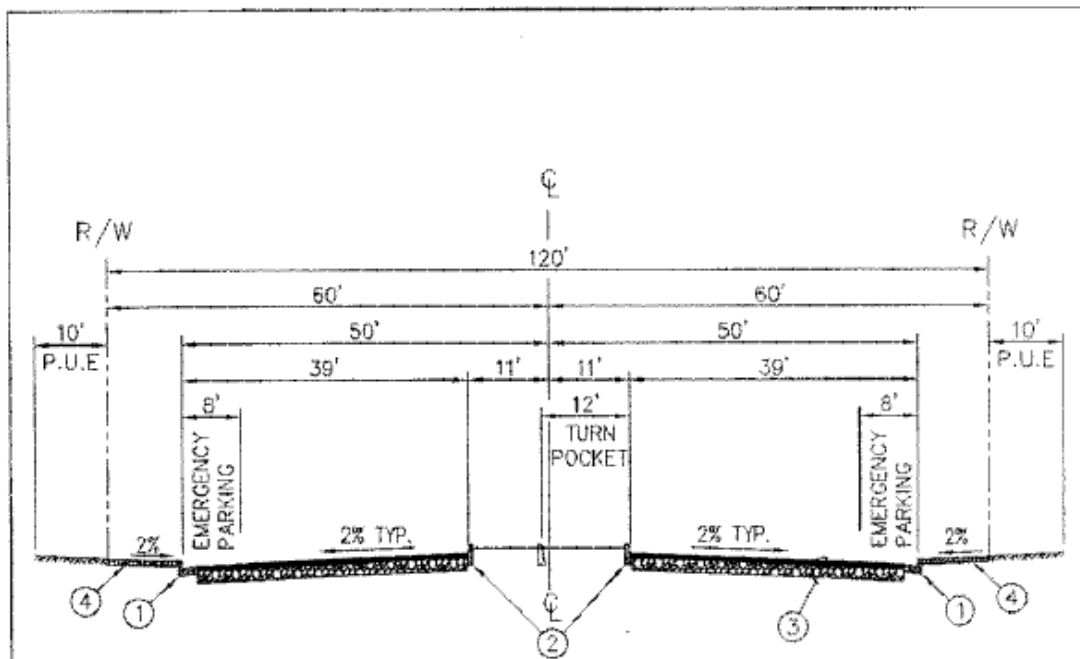

- ① TYPE "B" (8") CURB AND GUTTER PER STANDARD DRAWING S-8, UNLESS OTHERWISE APPROVED
- ② TYPE "D" (8") BARRIER CURB PER STANDARD DRAWING S-10.
- ③ STREET SECTION PER APPROVED DRAWINGS; MINIMUM 4" A.C. ON 12" CL2 AGGREGATE BASE.
- ④ SIDEWALK PER STANDARD DRAWING S-25.1

P.U.E. = PUBLIC UTILITY EASEMENT
 C = CENTERLINE OF R/W
 R/W = RIGHT-OF-WAY WIDTH

CITY OF COACHELLA

APPROVED:		
<i>[Signature]</i>		
RCE 24890	EXP. 12/31/07	
REVISION	APPROVED	DATE

**EXPRESS WAY
120' RW**

STANDARD DRAWING NO.
S-1
JUNE 2007

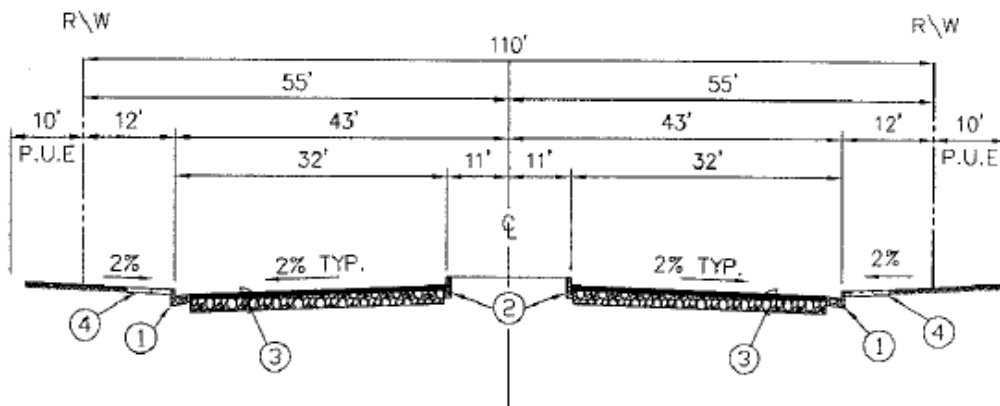

- ① TYPE "B" (8") CURB AND GUTTER PER STANDARD DRAWING S-8, UNLESS OTHERWISE APPROVED
- ② TYPE "D" (8") BARRIER CURB PER STANDARD DRAWING S-10.
- ③ STREET SECTION PER APPROVED DRAWINGS; MINIMUM 4" A.C. ON 12" CL2 AGGREGATE BASE.
- ④ SIDEWALK PER STANDARD DRAWING S-25.1

P.U.E. = PUBLIC UTILITY EASEMENT
 CL = CENTERLINE OF R/W
 R/W = RIGHT-OF-WAY WIDTH

CITY OF COACHELLA

APPROVED:		
<i>[Signature]</i>		
RCE 24800	EXP. 12/31/07	
REVISION	APPROVED	DATE

**MAJOR ARTERIAL
 110' R/W**

STANDARD DRAWING NO.
S-2
JUNE 2007

W:\PUMPS\STDS NEW\SUBSET\Standard Drawings\COA-32 6/20/2007 2:35 PM

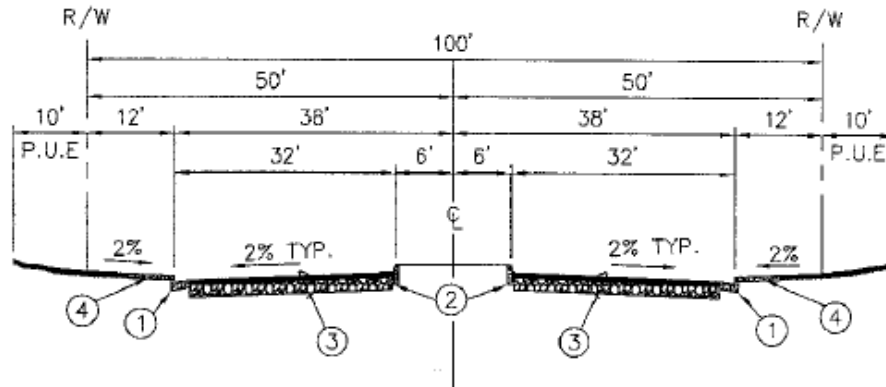

- ① TYPE "B" (8") CURB AND GUTTER PER STANDARD DRAWING S-8, UNLESS OTHERWISE APPROVED
- ② TYPE "D" (8") BARRIER CURB PER STANDARD DRAWING S-10.
- ③ STREET SECTION PER APPROVED DRAWINGS; MINIMUM 4" A.C. ON 10" CL2 AGGREGATE BASE.
- ④ SIDEWALK PER STANDARD DRAWING S-25.1

P.U.E. = PUBLIC UTILITY EASEMENT
 C = CENTERLINE OF R/W
 R/W = RIGHT-OF-WAY WIDTH

CITY OF COACHELLA

APPROVED: *[Signature]*
 RCE 24870 - EXP. 12/31/07

REVISION	APPROVED	DATE

**MINOR ARTERIAL
 100' R/W**

STANDARD DRAWING NO.
S-3
JUNE 2007

W:\JUNWIS\STD5 NEW CLINEX\Standard Drawing\COA-S3 6/20/2007 2:38 PM

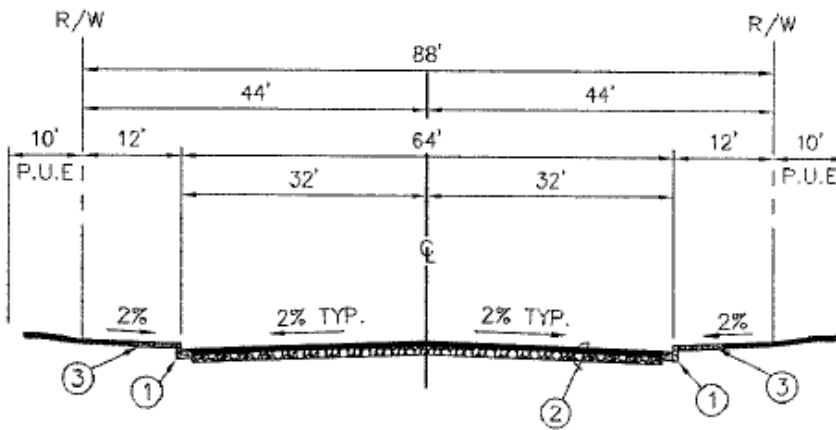

- ① TYPE "A" (6") OR "B" (8") CURB AND GUTTER PER STANDARD DRAWING S-7 OR S-8, UNLESS OTHERWISE APPROVED
- ② STREET SECTION PER APPROVED DRAWINGS; MINIMUM 4" A.C. ON 10" CL2 AGGREGATE BASE.
- ③ SIDEWALK PER STANDARD DRAWING S-25.1

W:\PUBWKS\STDS NEW DUBDI\Standard Drawings\COM-S4 6/20/2007 2:39 PM

P.U.E. = PUBLIC UTILITY EASEMENT
 CL = CENTERLINE OF R/W
 R/W = RIGHT-OF-WAY WIDTH

CITY OF COACHELLA

APPROVED:		
<i>[Signature]</i>		
RCE 24870 EXP 12/31/07		
REVISION	APPROVED	DATE

MAJOR COLLECTOR
88' R/W

STANDARD DRAWING NO.
S-4
JUNE 2007

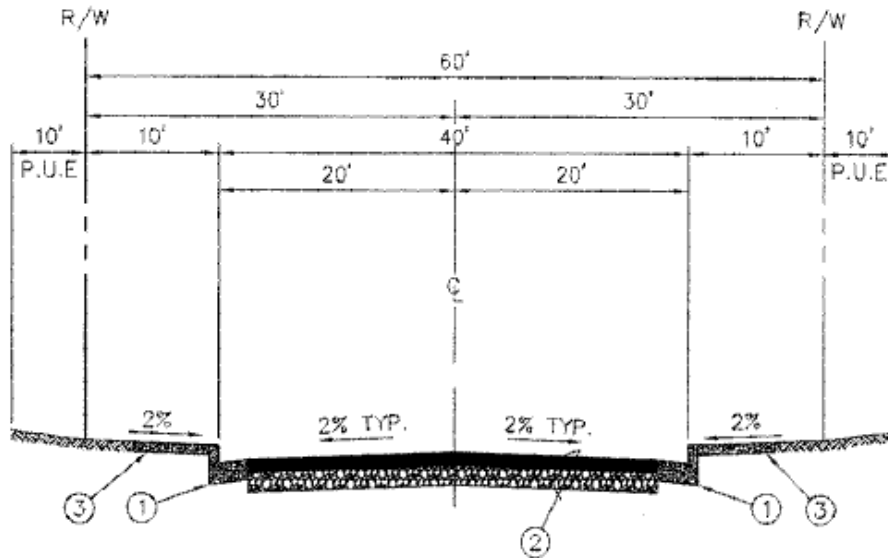

- ① TYPE "A" (6") OR "B" (8") CURB AND GUTTER PER STANDARD DRAWING S-7, S-8 OR S-9
- ② STREET SECTION PER APPROVED DRAWINGS; MINIMUM 3" A.C. ON 6" CL2 AGGREGATE BASE.
- ③ SIDEWALK PER STANDARD DRAWING S-25.1

W:\PROJECTS\2007\1000\Standard Drawings\USA-S5 6/29/2007 2:49 PM

P.U.E. = PUBLIC UTILITY EASEMENT
 C = CENTERLINE OF R/W
 R/W = RIGHT-OF-WAY WIDTH

CITY OF COACHELLA

APPROVED:		
<i>[Signature]</i>		
RCE 24870	EXP. 12/31/07	
REVISION	APPROVED	DATE

**MINOR COLLECTOR
 RESIDENTIAL
 60' R/W**

STANDARD DRAWING NO.
S-5
JUNE 2007