

| TABLE "A" RAFTER SPANS (DOUGLAS FIR #2 OR BETTER) | | |
|--|----------|------------|
| SIZE | SPACING | SPAN |
| 2 x 4 | 12" O.C. | 9' - 10" |
| | 16" O.C. | 8' - 11" |
| | 24" O.C. | 7' - 8" |
| | 32" O.C. | *6' - 3" |
| 2 x 6 | 12" O.C. | 15' - 4" |
| | 16" O.C. | 13' - 9" |
| | 24" O.C. | 11' - 3" |
| | 32" O.C. | *9' - 7" |
| 2 x 8 | 12" O.C. | 20' - 0" |
| | 16" O.C. | 18' - 2" |
| | 24" O.C. | 14' - 10" |
| | 32" O.C. | *12' - 8" |
| 2 x 10 | 12" O.C. | 20' - 0" |
| | 16" O.C. | 20' - 0" |
| | 24" O.C. | 18' - 11" |
| | 32" O.C. | *16' - 2" |
| 4 x 4 | 24" O.C. | 10' - 0" |
| | 32" O.C. | *9' - 3" |
| | 48" O.C. | *7' - 8" |
| 4 x 6 | 24" O.C. | 15' - 11" |
| | 32" O.C. | *13' - 9" |
| | 48" O.C. | *11' - 3" |
| 4 x 8 | 24" O.C. | 20' - 0" |
| | 32" O.C. | *18' - 2" |
| | 48" O.C. | *14' - 10" |

| TABLE "B" HEADER SIZE & SPANS (DOUGLAS FIR #2 OR BETTER) | | |
|---|------------|--------|
| RAFTER SPAN | HEADER | |
| | SPAN | SIZE |
| UP TO 12'-0" | 8'-0" MAX | 4 x 6 |
| | 10'-0" MAX | 4 x 8 |
| | 12'-0" MAX | 4 x 10 |
| | 14'-0" MAX | 4 x 12 |
| 12'-1" TO 20'-0" | 8'-0" MAX | 4 x 8 |
| | 10'-0" MAX | 4 x 10 |
| | 12'-0" MAX | 4 x 12 |
| | 14'-0" MAX | 4 x 14 |

| TABLE "C" FOOTING SIZE |
|---|
| BASED ON 1000 P.S.F. SOIL BEARING PRESSURE. |
| 18" SQ. X 12" DEEP |
| 18" SQ. X 12" DEEP |
| 18" SQ. X 12" DEEP |
| 18" SQ. X 12" DEEP |
| 24" SQ. X 12" DEEP |
| 24" SQ. X 12" DEEP |
| 24" SQ. X 12" DEEP |
| 24" SQ. X 12" DEEP |

| TABLE "D" LEDGER BOLTING Δ |
|--|
| ALL LAG BOLTS SHALL HAVE 1/4" PRE-DRILLED HOLES - (SEE NOTE 2) |
| 1/2" DIA. X 5" LONG AT 16" O.C. STAGGERED |
| (2) 3/8" DIA X 5" LONG AT 16" O.C. |

NOTES:

- TWO 2X MEMBERS MAY BE SUBSTITUTED FOR ONE 4X HORIZONTAL FRAMING MEMBER.
- LAG BOLTS MUST FULLY ENGAGE A WOOD STUD OR RIM JOIST AND BE PROVIDED WITH APPROPRIATE WASHERS. LAG BOLTS SHALL BE LOCATED A MINIMUM OF 1-1/2" FROM THE TOP OR BOTTOM OF THE LEDGER.
- NOT DESIGNED TO BE ENCLOSED - ADDITIONAL ENGINEERING ANALYSIS WILL BE REQUIRED IF ENCLOSED.
- SEE PAGE 2 OF 2 FOR CONSTRUCTION DETAILS.
- ARTIFICIAL LIGHTING IS REQUIRED IN ROOMS THAT HAVE WINDOW OPENINGS INTO THE COVERED PATIO AREA IF THE TOTAL WINDOW AREA IN THAT ROOM IS LESS THAN 10% OF THE FLOOR AREA OF THE ROOM OR 20 SQUARE FEET, WHICHEVER IS GREATER. Δ

DISCLAIMER:

ALTERNATE PATIO DESIGNS MAY BE POSSIBLE WHEN PROVIDED WITH AN ENGINEERED ANALYSIS. USE OF THIS CONVENTIONAL STANDARD DESIGN IS AT THE USER'S RISK AND CARRIES NO IMPLIED OR INFERRED GUARANTEE AGAINST FAILURE OR DEFECTS.

* THIS SPACING AND SPAN IS FOR LATTICE PATIO COVERINGS ONLY.

| | |
|---|--|
| WESTERN RIVERSIDE COUNTY CODE UNIFORMITY PROGRAM | |
|  | CITY OF COACHELLA BUILDING & SAFETY |
| PATIO COVER STANDARD | |
| (760)398-3002 | 53-990 ENTERPRISE WAY COACHELLA, CA 92236 |
| | PAGE 1 OF 2 |

KNEE BRACE DETAIL AT END POSTS

(REQUIRED WHEN RAFTER SPAN EXCEEDS 12 FT.)

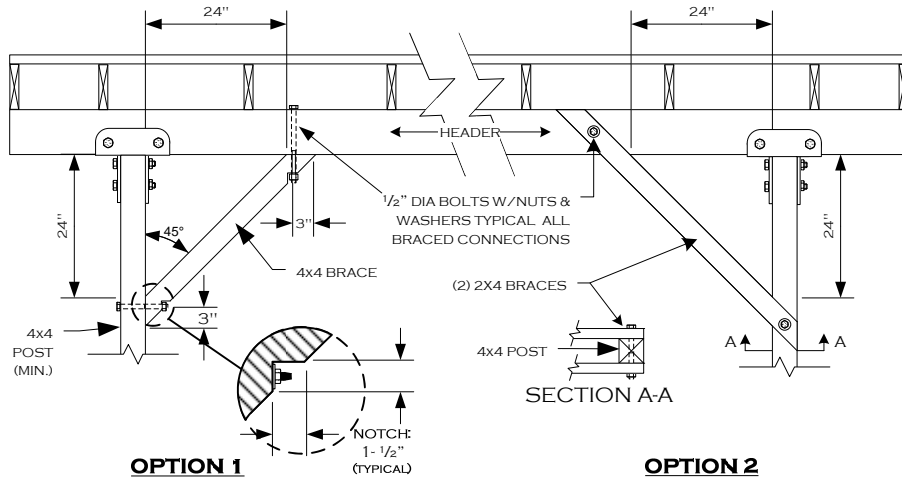

LEDGER ATTACHMENT

DETAIL

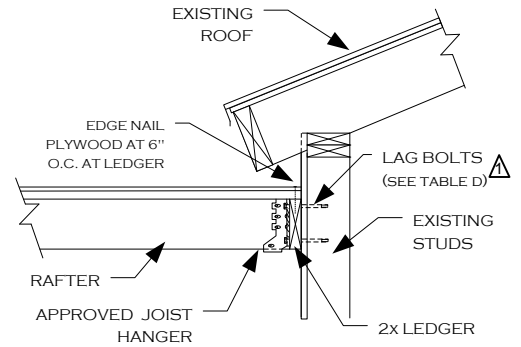

NOTES:

1. USE A CONTINUOUS 2X LEDGER – SAME DEPTH AS RAFTER OR LARGER
2. SEE TABLE "D" FOR BOLTING REQUIREMENTS

INVERTED HEADER DESIGN OPTION (LATTICE ONLY)

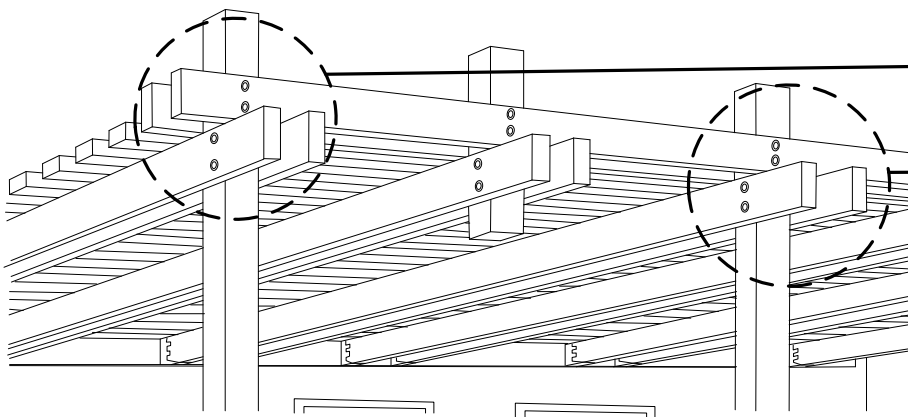

NOTE: KNEE BRACING REQUIRED WHEN RAFTER SPAN EXCEEDS 12 FEET

2X FASCIA (OVERHANG) ATTACHMENT – LATTICE ONLY

OPTION 1

OPTION 2

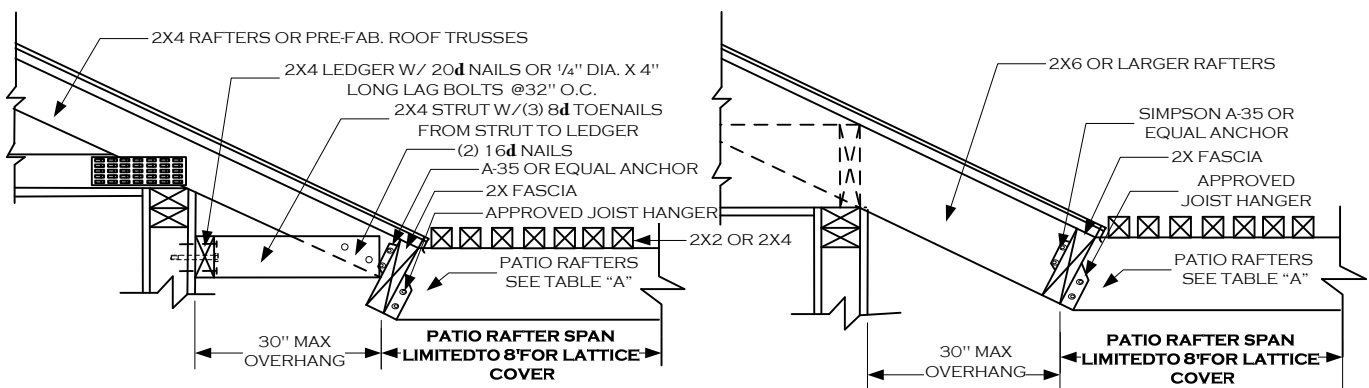

NOTE: VERIFY STRUCTURAL SOUNDNESS OF ROOF RAFTERS FOR DECAY OR TERMITE DAMAGE, AND REPLACE WITH LIKE MATERIALS AS NEEDED, AFTER CONSULTATION WITH THE BUILDING DEPARTMENT.

WESTERN RIVERSIDE COUNTY CODE UNIFORMITY PROGRAM



CITY OF COACHELLA
BUILDING & SAFETY

PATIO COVER STANDARD

(760)398-3002

53-990 ENTERPRISE WAY
COACHELLA, CA 92236